

# Analyzing the Influence of the Construction Element Position on Torque Transmission by Friction

M. Jeremić<sup>a</sup>, M. Matejić<sup>a</sup>, B. Bogdanović<sup>a</sup>, B. Tadić<sup>a</sup>, D. Miloradović<sup>a</sup>, D. Miljanić<sup>b</sup>

<sup>a</sup>Faculty of Engineering, University of Kragujevac, Sestre Janjić 6, Kragujevac, Serbia,

<sup>b</sup>Metalik DOO, Trebjeska 6, Niksic, Montenegro.

## Keywords:

Frictions,  
Wear  
Transfer of torque  
Special device  
Marine winch drum

## ABSTRACT

*This paper is analyzing the impact of the construction element position of ship winch drum on the effects of torque transmission by friction in the mechanization welding process. The driving and driven wheels (construction elements) were examined for the general case of the load distribution. Based on this examination, the construction of the device that should provide the reliable torque transmission and the movement of the drum in the process of its welding are proposed. This construction is characterized by a high level of flexibility and ability to change the friction torque based on changing drum position in regard to the driving and driven wheels (construction elements). With this new construction, problems related to the movement synchronization are avoided, unlike the all previously known constructions of this type, which lead to the positive impact on the wear intensity of friction gears.*

## Corresponding author:

Marija Jeremić  
Faculty of Engineering,  
University of Kragujevac,  
Sestre Janjić 6,  
Kragujevac, Serbia  
E-mail: marija.jeremic@kg.ac.rs

© 2014 Published by Faculty of Engineering

## 1. INTRODUCTION

Research described in the paper is related to the problems of friction torque transmission. Research is applicative and connected with design of boot device (reversal) drum ship winches during welding process. Torque transmission is performed by friction tribological contact with rubber and metal. Movement can be reached by using only the effects of friction, but friction during movement always brings different types of losses. Connected with this, knowledge of the value of coefficient of friction is very important for every engineer and designer who is involved in design and development of mechanical structures,

which perform their function through interaction of surfaces which move relatively. It is well known that the process of friction follows every kind of body movement. Friction is a necessary process because only with effects of friction can be achieved starting, moving, changing speed or stopping. On the other hand, during movement, as a consequence of frictional resistance, that resistance must be overcome in order to continue movement, which is why the energy losses exist. In addition to energy loss, friction is always accompanied with wear of material on contact surfaces, which produces an additional costs and loss of functionality of elements in contact.

Friction is, therefore, such a process which, at the same time, manifests positive and negative effects. It is therefore natural that there is a tendency to eliminate its negative effects, or at least minimize, and to increase the positive. A review of the knowledge of the friction force, as well as ways for measurement are presented by Peter J. Blau [1], he presented some of the most common standards-defined measuring methods for static and dynamic friction coefficient, and its potential uses. Beginning of movement of any kind is related to the existence of static friction. Static coefficient of friction depends of many parameters, especially from the surface of contact, normal load, and temperature of the atmosphere in which contact occurs, surface absorption, quality of contact surface materials [2-6]. Analyzing the rolling process [7] in the absence of any load, the conclusion is that the energy losses are result of collisions of two moving rolling mass, i.e. mass of rolling body with the body on whose surface is rolling. Rolling resistance of radial motion of the cylinder at flat surface was investigated in the paper [8]. Tested results showed that the coefficient of rolling friction depends on the speed of cylinder movement. At low speeds of cylinder, the coefficient of rolling friction increases due to increasing of substrate rate of deformation. For higher speeds, however, the coefficient of rolling friction is reduced, thereby lowering the area of the deformed surface. Persson et al [9] study the sliding friction for viscoelastic solids, e.g., rubber, on hard flat substrate surfaces. Consider first the fluctuating shear stress inside a viscoelastic solid which results from the thermal motion of the atoms or molecules in the solid. At the nanoscale the thermal fluctuations are very strong and give rise to stress fluctuations in the MPa range, which is similar to the depending stresses which typically occur at solid-rubber interfaces, indicating the crucial importance of thermal fluctuations for rubber friction on smooth surfaces. Developed a detail model which takes into account the influence of thermal fluctuations on the depending of small contact patches at the rubber-substrate interface. The experiment led to the conclusion that the amplitude of the surface roughness has a very small effect of friction sliding rubber. The coefficient of friction of rubber is highly dependent on normal load [10] and thus contacts pressure. The effects of carbon and

cellulose fibers on the tribological characteristics of rubber-based friction materials examined Akbar et al in his paper [11]. Experimental research of static friction of footwear rubber samples and different types of floor materials is presented in the paper [12]. Friction tests realized with different sliding speeds and different temperatures, with the examination of the microstructure and mechanical properties of the surfaces in contact. Experimental results showed that carbon fibers had a minor effect on the coefficient friction, but that increase wear resistance. Shanahan et al [13] investigated the mechanism of adhesion that occurs in the contact pair rubber and hard metal rolling bodies. The high degree of adhesion can be apparent even at room temperature if the contact time and pressure reach sufficient values. Based on obtained results it was determined that energy, which is dissipated during rolling, refers not only to the influence that accompanies hysteresis adhesive separation, but also to the losses caused by loading with large cylinder. The nature of friction between the rubber and the solid substrate is very important for many technical applications. Friction of rubber is significantly different from the friction between hard substances such as metals and ceramics. In the paper [14] it was proved that the tire has significantly favorable friction characteristics.

In order to optimize the construction were performed large number of theoretical considerations and preliminary ideas were done for a detailed review and analysis of the literature that examines this issue. Research is based on determining the transmission of torque from the special device on marine winch drum, which is done by means of friction between rubber and metal.

## **2. CONCEPTUAL DESIGN OF ROTATING EQUIPMENT FOR WELDING**

An important aspect of implementing of any automated system to the manufacturing process is its price. Because of that, design should be analysed in detail determining which parts of the technical system are not meaningful to automate. To define the appropriate general design, project starts with the technical requirements of the product, discusses design

solutions of existing products with similar functions (Fig. 1). Drive of rotary positioner shown is realized by two electric motors and gears, because speed and variable speed drive is required. The principle of operation of the electric motor which drives pieces of the structure requires ensuring synchronization of movement, which is serious theoretical and practical problem.



Fig. 1. Rotating positioner.

Especially when the chain transfers torque transmission is based on the basis of friction. The requirement for the proper operation of structures, in the presence of synchronization, is that the motors are with the same characteristics. One of the problems of providing synchronized movement is the possible difference of phases of propulsion motors. In addition, great equalization currents can occur that can cause permanent deformation of the motor coils. In addition to these phenomena can occur torque on the wheel axle, which can cause even shaft breakage. If there is a significant phase shift of motors, engines must be harmonized, which means, must be speed up or slow down. The problem of not synchronized movement has a particularly negative impact on the frictional wear of the drive wheels.

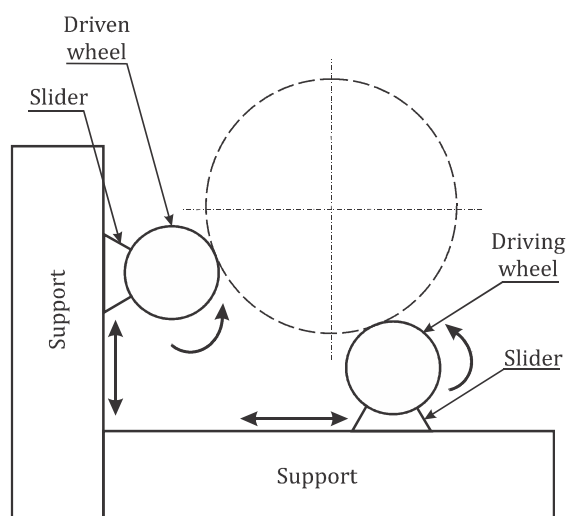

Fig. 2. Conceptual design of construction.

Conceptual principally solution system Apogon drum marine winch, during the drafting process is shown in Fig. 2. General function of rotational structure is achieved (Fig. 2) executing a series of partial functions. Rotary positioner is composed of more machine parts, sub-assemblies, subgroups and groups linked to a functional unit. A flexible shaft coupling is interconnected with the shaft and wheels so the torque and power from the engine is transmitted from one shaft to another point. Driven wheels rotating function performed under the influence of rotation of the drum. Frames construction, rely on a base that is used to keeping a distance between frames is realized, depending on the needs of the fastener.

### 3. ANALYSIS OF FORCES ON TRANSMISION

Dimensioning of steel structures is performed based on knowledge of layout external actions (forces and moments). Determining the ability of construction to convey given loads of force is based on the characteristics of the materials used and the allowable stress. Allowable stresses are prescribed for the steel structure and functions are determined by the choice of the material and the character of the external load. Calculation of the construction is proof load and usability of the structure under the influence of prescribed load during the life time of construction. The process of designing, calculating and dimensioning of construction is actually choice of a calculation model to credibly describe the real behaviour of the structure under the prescribed load, but taking into account the optimal complexity of the model, the possibility to calculate the performance and profitability of individual parts of the structure. This work studied the loads that occur in the system. System shown in Fig. 3 was examined as static system, i.e. system at rest state and the conditions that enable this state are used. External cause (external effects) on the solid body is the force that causes a change in sleep mode and the motion of the system. For the analysis of the effects of forces in the specific example of the drum with diameter  $D=1000$  mm and length  $l=2000$  mm load is the weight of the drum, which is  $G=50000$  N. Based on these data dimensions of construction were developed. It is necessary to determine the load distribution, especially load of friction wheel as a function of

drum position (Fig. 3). Rotary positioner is designed that at work most of the weight rests on the drum drive wheel. The whole system is viewed as a horizontal system which is attached to the substrate. In this case, the main task is reduced to the determination of the resistance of the supports and the force of friction.

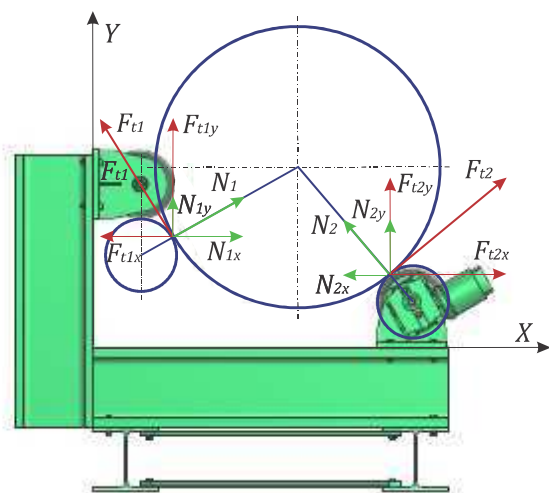

Fig. 3. Schedule forces on the maximum size of the drum.

In the beginning problem is solved imagining that the supports are removed and replaced by their action forces called resistance actions, as in this case the normal force wheels  $N_1$  and  $N_2$ . It analyses the effect of the friction forces that appear between the drum and wheel. How there are different materials in the contact zone, i.e. the interaction between the rubber and steel, the coefficients of friction  $\mu$  is different. Connected with this, for the sliding friction, apropos coefficient of friction between the drive wheel and the drum takes the value  $\mu_s=0.6$ , and the value of coefficient of rolling friction between the driven wheels and drums  $\mu_{roll}=0.05$ . As a starting basis for solving given problem is the determination of friction force from the equation:

$$F_{t1} = N_1 \cdot \mu_1 \quad (1)$$

$$F_{t2} = N_2 \cdot \mu_2 \quad (2)$$

In order that observed system was in equilibrium, the resultant of all the forces must be equal to zero. Since in the observed case of action of horizontal and vertical forces, this implies two equilibrium conditions.

$$\sum_{i=1}^n x_i = 0 \quad \text{and} \quad \sum_{i=1}^n y_i = 0$$

From the previous two conditions can be calculated unknown resistance supports  $N_1$  and  $N_2$ . It's actually a system of two equations with two unknowns. The first condition of equilibrium is the sum of all components of the forces which act horizontally in the direction of the x axis is equal to zero:

$$\sum_{i=1}^n x_i = F_{t2x} - N_{2x} + N_{1x} - F_{t1x} = 0 \quad (3)$$

Where are:  $F_{t1x}$ ,  $F_{t2x}$ ,  $N_{1x}$  and  $N_{2x}$  projection force  $F_t$  and  $N$  on the x axis.

The second condition is the sum of all forces which acting vertically on the given system is equal to zero:

$$\sum_{i=1}^n x_i = F_{t1y} - N_{2y} + N_{1y} - F_{t2y} - mg = 0 \quad (4)$$

Further analysis of the static equations depending on the angles  $\varphi_1$  and  $\varphi_2$  that are within the values of  $65^\circ$  to  $82^\circ$  for angle  $\varphi_1$  i.e. from  $38^\circ$  to  $47^\circ$  for angle  $\varphi_2$  to get possible values of the forces that are shown in Table 1.

Table 1. The dependence the force of angle  $\varphi_1$ .

The dependence the friction force and the resistance supports on the angle $\varphi_1$
$F_{t1x} = -N_1 \cdot \mu_1 \cdot \cos \varphi_1$ $F_{t1y} = N_1 \cdot \mu_1 \cdot \sin \varphi_1$ $N_{1x} = N_1 \cdot \cos(90 - \varphi_1)$ $N_{1y} = N_1 \cdot \sin(90 - \varphi_1)$
The dependence the friction force and the resistance supports on the angle $\varphi_2$
$F_{t2x} = N_2 \cdot \mu_2 \cdot \cos \varphi_2$ $F_{t2y} = N_2 \cdot \mu_2 \cdot \sin \varphi_2$ $N_{2x} = -N_2 \cdot \cos(90 - \varphi_2)$ $N_{2y} = N_2 \cdot \sin(90 - \varphi_2)$

The final expressions for the calculation of reaction to friction wheels are:

$$N_2 = N_1 \frac{\mu_1 \cdot \cos \varphi_1 - \cos(90 - \varphi_1)}{\mu_2 \cdot \cos \varphi_2 - \cos(90 - \varphi_2)} \quad (5)$$

$$\frac{\mu_1 \cdot \cos \varphi_1 - \cos(90 - \varphi_1)}{\mu_2 \cdot \cos \varphi_2 - \cos(90 - \varphi_2)} = k \quad (6)$$

where  $k$  is a dimensionless coefficient. A static equilibrium condition for the  $y$  axis is:

$$N_1 = \frac{mg}{k \cdot \mu_2 \cdot \sin \varphi_2 + k \cdot \sin(90 - \varphi_2)} + \frac{mg}{\mu_1 \cdot \sin \varphi_1 + \sin(90 - \varphi_2)} \quad (7)$$

$$N_2 = N_1 \cdot k \quad (8)$$

$$F_{t1} = N_1 \cdot \mu_1 \quad (9)$$

$$F_{t2} = N_2 \cdot \mu_2 \quad (10)$$

Showing force intensity in depending on the changes of angles, i.e. depending on the position of the drum, and with the same diameter and weight of the drum, were calculated and are presented in Table 2.

**Table 2.** Force intensities depending on the angles.

$\varphi_1$	$\varphi_2$	$N_1$ [kN]	$N_2$ [kN]	$F_{t1}$ [kN]	$F_{t2}$ [kN]
82	38	6.03	41.41	0.30	24.85
80	39	6.88	41.16	0.34	24.70
78	40	7.75	40.88	0.39	24.53
76	41	8.61	40.55	0.43	24.33
74	42	9.48	40.19	0.47	24.11
72	43	10.35	39.79	0.52	23.87
70	44	11.22	39.35	0.56	23.61
68	45	12.11	38.87	0.61	23.32
66	46	12.99	38.35	0.65	23.01
65	47	13.83	38.01	0.69	22.80

Based on analysis of obtained values of the normal forces and frictional force from Table 1, it can be observed that for settings in any position, the highest intensity have a force  $N_2$ , i.e. maximum load is on the drive wheels. Based on comparative analysis calculation, as well as most of the calculation that are not shown in this paper, dependence of driving force (friction force) in the function of the drum position is established, i.e. dependence of angles  $\varphi_1$  and  $\varphi_2$ . This dependency of the complex form  $F_{t2}=f(\varphi_1, \varphi_2)$  is shown in the diagram, which is shown in Fig. 4.

It can be seen from the diagram that the function reaches a very high values of the force intensity around angles  $\varphi_1$  and  $\varphi_2$  which are close to 90°. It is obvious that this is a so-called wedge effect, which occurs at extremely high intensity of

tangential force. Ostensibly, this "extreme function" can be good solution from the driving forces aspect.

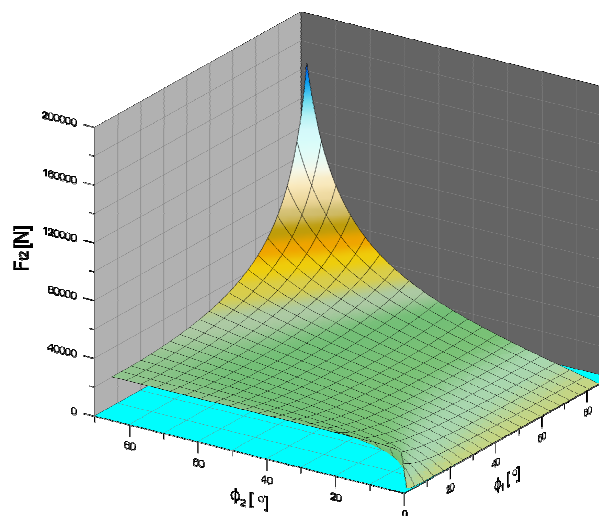

**Fig. 4.** Diagrammatic representation of the dependence of the friction drive wheel of the angles.

However, to achieve such high values of driving force, the system must be exposed to very high values of normal load, in the order of 20 kN. The application of such high load is very problematic in terms of the allowable stress levels between the drum and drive wheel. For this reason, the authors find that the angles of  $\varphi_1$  and  $\varphi_2$  should be chosen in a range with much lower values, with which will not be intensive wear and will be ensured stability of device.

#### 4. CONSTRUCTIVE SOLUTION OF DEVICE

Calculation of the structure derived in the previous section proves portability and usability of the structure under the influence of prescribed load during the life time of construction. Concept of special device (device for propositioning and rotation of drum during manufacturing process) presented has as main function of torque transfer (power) on the basis of friction between rubber and steel elements that are in direct contact. To ensure the power transfer, it is necessary that the force of friction is greater than torque on the wheels. In the process of development as well as design structure shown, estimate segment of profitability aspect is a key element in the design. This type of positioner is specifically designed and manufactured for the purpose of increasing productivity, reducing the intensity



for the welder, because all the welding process can be performed automatically. Welding head is managed by welder, while workpiece rotates. Welding circular cylinder (drum), using a crane to set the adjustable rollers trolley. The distance of cart can adjust the size of the cylinder. In Fig. 5, the different dimensions of the drum can be set on the positioner.

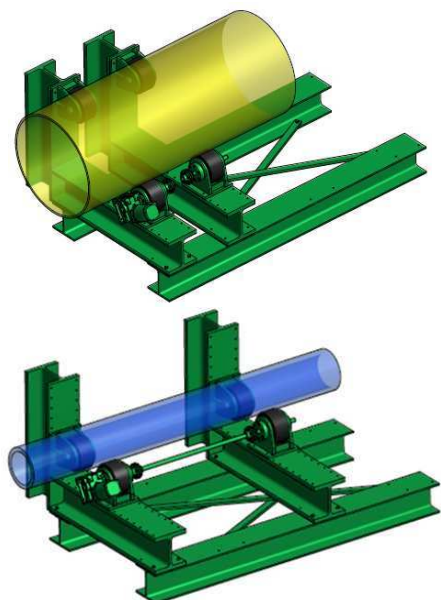

Fig. 5. Different sized drum set up in the positioner.

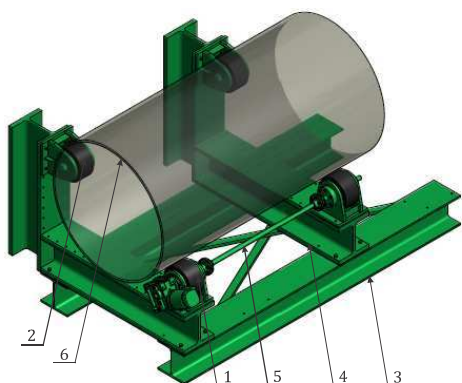

Fig. 6. Rotary positioner assembly: 1- wheel drive, 2- driven wheel, 3 - base, 4- frame positioner, 5 - flexible shaft, 6 - drum.

The distance between the rollers can be, depending on needs, set by screw. Movement of rolls is possible in horizontal and vertical direction of the positioner frame. Drive for rollers are accomplished with one electric motor, which reduces the speed by worm gear. Operation of the second part of the carriage is achieved by a flexible shaft. In this way using of fluid power the synchronization of engine is avoided. Using a positioner in the production

process, which gives high efficiency and cheaper process of welding, has the characteristics of light, reliability, performance and wide field of applications. Workpieces are therefore placed in the best possible way and in the most favourable position in relation to the welders, and on the basis of technical documentation.

Rotary positioner (Fig. 6) is composed of a number of mechanical parts, sub-assemblies, and sub-groups linked to a functional unit. Drive wheel (position 1) is one of the main structural elements and plays an important role in the performance of functions. Casing point consists of sides and base which are welded together. Beside the basic function to combine elements and enable the proper functioning of the wheel, housing need to protect wheel from external influence. During welding of sides parallelism should be taken into account to ensure that shaft, which is fitted in the openings from sides, can smoothly perform their function. Shaft allows rotating of all parts which are there, assembling at functional unit and transferring loads. Given that the direction of external loads are vertically, for reliable operation of the wheel radial bearings are fitted. Both bearing are protected against atmospheric agents' with cups. Worm gear with electric motor serves to transmit power from the engine to the working machine, and to adjust rotational speed and torque needed for shaft. Subassembly of driven wheel (position 2) is easily derived as opposed to the drive wheel subassembly. For the purpose of stiffening the case, it is necessary to construct the corresponding ribs. In this case the stationary shaft and pressed through the opening of sides, the wheel while under the influence of the load rotates around it. The wheels are made of steel coated with rubber; where rubber has a function to reduce wear process. At the ends of the shaft exist thread for nut and washer which locates bearing. The distance between the bearing housing and sides is provided with spacers. As each object, in general, can be created in several ways, analysis of possible variants is done from optimal solution is selected. Standard steel profiles are used for base (position 3). Length of profile is chosen optimally, based on the analysis of cases in terms of parameters essential for the performance of the drafting process. The main function of the base is to ensure the proper conduct of frame structures without the

possibility of drift during operation. The connection between the frame and the base is accomplished by means of threaded joints. Parallelism of the guide is provided with two rods, which are connected with bolts to linear guides. Frame positioner (position 4) is an important element of the structure. It consists of two standard steel profiles assembled by welding. The function of the frame is to connect wheels into one functional unit. Safety and reliability depends on the position of the wheels and safety and reliability of threaded fasteners. Nuts and bolts are used to connect subassembly of wheels with frame. Movement of the wheels enables frame length and the distance depends on the size of the drum being processed.

## 5. DISCUSSION

The introduction of new design into the production process has many advantages which are shown as follows:

- Improving the quality of welded joints is achieved thereby enabling semiautomatic welding. During rotation of the positioner, the worker can freely perform single-pass welding continuously, without interruption of the welding. The process is repeated until the drum is fully welded at the site.
- Reduced the preparatory time during welding.
- Increase in profit resulting from reduced preparation time. Based on the review, with the introduction of the positioner, it is possible to produce two winches on the year, which also means, that the introduction of new design will paid in a short period of time.
- Technical features of the structure are such that it is possible to perform the procedure on the positioner gas cutting, as well as welding.

Reengineering processes need to improve organizational structure, to allow the replacement of long-term measures and measures to make quick and drastic changes to increase the quality, reduce the cost, reduce execution time of the process, improve internal and external relationships, eliminate unnecessary activities, provide a pleasant atmosphere for work and eliminate unnecessary activities.

## 6. CONCLUSIONS

From review of the literature sources related to the considered problem, it can be concluded that this area of research is very complex. Here is presented concept of development of special products (devices for positioning and rotation of the drum), based on knowledge of engineering science group. In order to optimize the construction, theoretical considerations made a number of conceptual designs and prepared a detailed review and analysis of the literature that examines this issue. The proposed solution does not require synchronization device for movement of two drive motors, which is a particular problem, which is discussed in the paper. The inclusion of a special device, designed for the production gets reduced value processing, minimum use of materials, better quality and more reliable weld construction winches. The authors are inclined to think that a proper choice of frame and accessory devices for positioning, funds can be recovered at the level of the two-year. It should be noted that this positioner which is semiautomated has positive effects on welding proces in terms of safety. In particular, if one takes into account that safety in the workplace is one of the most important categories of business in modern conditions of production. On the other hand, the structure is very efficient and suitable for wide application in industrial practice. A very important advantage of this design is that the machine can be made with a lot of low cost elements. If we look at design, it is more than clear that the design does not require a particularly high accuracy and precision manufacturing. It was tended to meet function durring design of device, to be easy for manufacture, to be easy for manipulation, to have lowest cost possible and to satisfy safety requirements.

## REFERENCES

- [1] Peter J. Blau: *The significance and use of the friction coefficient*, Tribology International, Vol. 34, No. 9, pp. 585–591, 2001.
- [2] K.-H. Zum Gahr, K. Voelker: *Friction and wear of SiC fiber reinforced borosilicate glass mated to steel*, Wear 225–229, No. 2, pp. 885–895, 1999.
- [3] P. Blau: *The significance and use of the friction coefficient*, Tribol. Int., Vol. 34, No. 9, pp. 585–591, 2001.

- [4] B. Ivkovic, M. Djurdjanovic, D. Stamenkovic: *The Influence of the Contact Surface Roughness on the Static Friction Coefficient*, Tribology in Industry, Vol. 22, No. 3&4, pp. 41-44, 2000.
- [5] U. Muller, R. Hauert: *Investigations of the coefficient of static friction diamond-like carbon films*, Surface and Coatings Technology, Vol. 174-175, pp. 421-426, 2003.
- [6] B. Polyakov, S. Vlassov, L.M. Dorogin, P. Kulis, I. Kink, R. Lohmus: *The effect of substrate roughness on the static friction of CuO nanowires*, Surface Science, Vol. 606, No. 17-18, pp. 1393-1399, 2012.
- [7] D.A. Desai: *What is rolling friction*, Resonance, Vol. 9, No. 12, pp. 52-54, 2004.
- [8] T. Pöschel, T. Schwager, N.V. Brilliantov: *Rolling friction of a hard cylinder on a viscous plane*, The European Physical Journal B - Condensed Matter and Complex Systems, Vol. 10, No. 1, pp. 169-174, 1999.
- [9] B.N. J. Persson, A.I. Volokitin: *Rubber friction on smooth surfaces*, The European Physical Journal E, Vol. 21, No. 1, pp. 69-80, 2006.
- [10] M.A. Chowdhurya, D.M. Nuruzzamana, A.H. Miaa, M.L. Rahaman: *Friction Coefficient of Different Material Pairs Under Different Normal Loads and Sliding Velocities*, Tribology in Industry, Vol. 34, No. 1, pp. 18-23, 2012.
- [11] A. Shojaei, M. Arjmand, A. Saffar: *Studies on the friction and wear characteristics of rubber-based friction materials containing carbon and cellulose fibers*, Journal of Materials Science, Vol. 46, No. 6, pp. 1890-1901, 2011.
- [12] D. Stamenković, M. Nikolić, M. Milošević, M. Banić, A. Miltenovića, M. Mijajlović: *Tribological Aspect of Rubber Based Parts used in Engineering*, Tribology in Industry, Vol. 36, No. 1, pp. 9-16, 2014.
- [13] M.E.R. Shanahan, N. Zaghzi, J. Schultz, A. Carré: *Hard Rubber/Metal Adhesion Assessment Using a Heavy Cylinder Rolling Test*, Adhesion 12, pp. 223-238, 1988.
- [14] V.L. Popov: *Rubber Friction and Contact Mechanics of Rubber*, Contact Mechanics and Friction, pp. 255-270, 2010.