

## IMPROVEMENT OF THE SPENSION SYSTEM OF THE WAGONS WITH LAMINATED SPRINGS\*

UDC 629.004.68

**Dragan Petrović<sup>#</sup>, Milan Bižić**

University of Kragujevac, Faculty of Mechanical Engineering Kraljevo, Kraljevo, Serbia

<sup>#</sup>E-mail: petrovic.d@mfkv.kg.ac.rs

**Abstract.** *In the exploitation of the laminated-spring freight wagons, a large number of suspension element fractures are detected. These fractures decrease transportation efficiency and are very often the cause of derailment with large economic losses and sometimes even those of human lives. This paper presents a failure analysis as well as that of the laminated-spring wagons' suspension improvement. The technique is based on specially designed rubber elastic elements which can be subsequently installed in the wagon suspension. This solution is the result of many years of research studies at the Railway Vehicles Centre of the Mechanical Engineering Faculty of Kraljevo in this field. The rubber elastic element is very easy to install in all the existing wagons, between the laminated-spring buckle and the underframe. The applied methodology is based on theoretical and experimental analysis of behaviour of the suspension with and without rubber elastic elements. Subsequent installation of rubber elastic elements can prevent very frequent fractures of laminated springs and cracks on the underframes. This provides for enormously reduced costs of wagon's maintenance as well as for an increased railway transportation efficiency.*

**Key words:** *Improvement, Suspension, Wagon, Laminated Springs*

### 1. INTRODUCTION

One of the most important parameters determining reliability and running safety of the railway vehicles is suspension functionality. In addition, it affects the quality of ride comfort of passengers or cargo. Inadequate functioning of the suspension causes very serious consequences and in many cases may cause derailment. For this reason, the fault of suspension is a very important topic that is the subject of many scientific papers such as [1–5]. The main aims of these research studies are to indicate potential problems and to motivate further improvements in the existing or newly-designed solutions of suspension.

---

Received April 11, 2012

\* **Acknowledgements.** The authors wish to express their gratitude to Serbian Ministry of Science and Technology for supporting this paper through the project TR35038.

This paper was presented at the *XV International Scientific-expert Conference on Railway RAILCON '12*, Faculty of Mechanical Engineering, Niš, Serbia, October 04-05, 2012.

Failures of the suspension system elements based on the laminated springs are particularly frequent when the wagons are used under extreme operating conditions. Very intense loadings in exploitation induce increasing stresses of these elements. As a consequence, there occur very frequently fractures of the suspension system elements as well as cracks on the underframe. Such fractures very often cause derailment, as it is, for example, shown in Fig. 1. Their impact is seen in huge material damage and significant decreasing of the railway freight transportation efficiency.

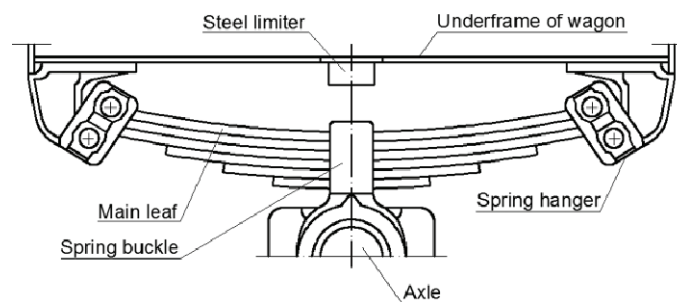

**Fig. 1** The derailment of a Fbd wagon for coal transportation in the thermal power plant "Nikola Tesla" Obrenovac, Serbia

The fracture occurrence has given rise to the need to improve the suspension system based on the laminated spring. The obtained results of the improvement based on the subsequent installation of a rubber elastic element are presented in this paper.

## 2. TYPICAL SOLUTION OF SUSPENSION BASED ON LAMINATED SPRING

The principal scheme of a typical solution of the suspension system based on the laminated spring is shown in Fig. 2.



**Fig. 2** The scheme of a typical solution of the suspension system based on the laminated spring

The steel limiter is fixed to the wagon's underframe and has the task to limit the stroke of the laminated spring. Under extreme operating conditions and at maximum loads there are intense dynamic rigid impacts of the spring buckle in the steel limiter which is very unfavorable for the suspension system and the wagon's underframe. As a result, there are very often fractures of the underframe and of the suspension system elements.

For example, for a Fbd wagon for coal transportation it is calculated that on average at the annual level, there are almost 3 fractures per wagon on the suspension system elements [6]. In addition, it is found out that the most dominant are the fractures of the laminated springs [6].

For the experimental tests of laminated springs of the Fbd wagon the following measuring equipment is used: the device for dynamic testing HBM MGC Plus, inductive displacement transducers HBM W100, and a PC. Also, the following software is used: the software package for data acquisition and on-line data processing - "Catman" (production of HBM), and the software package for processing and displaying data - "Origin" (production of MicroCal). Using the mentioned measuring equipment the behavior of laminated spring in the exploitation is recorded. During the tests, the vertical deflection (movement) of the spring buckle is measured. The collected data from exploitation are used to form a Goodman-Smith diagram and determine the lines of operating and the critical stresses of the laminated spring.

During the exploitation, the suspension system of the Fbd wagon is exposed to effects of forces  $F=F_{sr}+F_a$ . The mean load is  $F_{sr}=92.8 \text{ kN}$ , while the investigation reveals that the real values of total force  $F$  range also up to 50% above the average value, due to the overload of wheels and dynamic effects in motion. Therefore, the effect of amplitude load  $F_a$  on the fracture of the laminated spring is dominant.

The spectrum of the force amplitude or the stress of the laminated spring corresponds to the hard working regime. Based on the characteristics of the laminated-spring material (51Si7 according to EN) the line of the main dynamic strength is formed (dashed line on Fig. 3), where are:

$$\begin{aligned}\sigma_T &= 110 \div 125 \text{ kN/cm}^2 - \text{the yield strength,} \\ \sigma_{Dn} &= 60 \div 70 \text{ kN/cm}^2 - \text{the dynamic strength during the alternating variable load,} \\ \sigma_{Dj} &= 110 \text{ kN/cm}^2 - \text{the dynamic strength during the DC variable load.}\end{aligned}$$

The extreme values of these data ( $\sigma_T$ ,  $\sigma_{Dn}$ ) have low probability of occurrence, so in the further analysis the mean value of given areas are used.

The quality of the laminated spring production, the conditions of exploitation, and uniformity of loading are random variables, whose influence on the fracture is taken into account through the correction of the main dynamic strength by factor  $k_A$ . In that way, the line of the critical stress of the laminated spring is obtained (red line 1). On the other hand, the loads during the exploitation cause the stresses in the laminated spring of the following intensities:

$$\begin{aligned}\sigma_{sr} &= 55.38 \text{ kN/cm}^2 - \text{the medium dynamic stress in the laminated spring,} \\ \sigma_{max} &= 88.3 \text{ kN/cm}^2 - \text{the maximal dynamic stress in the laminated spring.}\end{aligned}$$

Changing of the operating stress of the laminated spring is linear and in the Goodman-Smith diagram it is represented by line 2 which passes through the origin and point K which has coordinates  $\sigma_{sr}$ ,  $\sigma_{max}$ . In this case the line of the operating stress of the lami-

nated spring cuts the line of the critical stress. From this analysis it can be concluded that in the existing state of the laminated spring the occurrence of the fracture is very likely. It is also concluded that occurrence of maximal stresses mostly affects the fractures of the main leaves of the laminated springs.

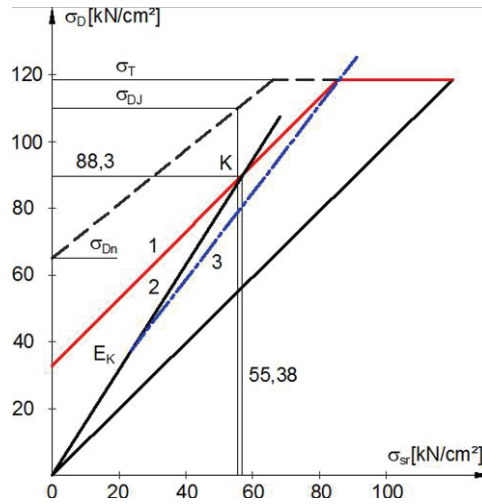
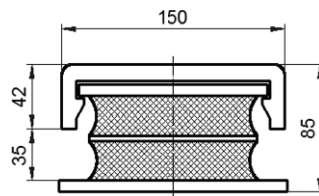

**Fig. 3** The Goodman-Smith diagram

Therefore, the main reasons for the fractures to occur are primarily increased stresses and loads as well as unreliable quality of the laminated spring production. In this case, the increased loads emerge, not only due to overload of wagons by coal, but also because of their uneven loading that cannot be accurately controlled.

### 3. SUBSEQUENT INSTALLATION OF RUBBER ELASTIC ELEMENT

In view of the existing wagon design, the special solution of the rubber elastic element, which can be subsequently installed in the suspension system, can be designed. In the specific example of the Fbd wagon this element is shown in Fig. 4. It is predicted that the life time of this element must be at least 5 years. What this provides for is the replacement of this element in the frame of the regular wagons' servicing.



**Fig. 4** The rubber elastic element

The element is very easy for installment in the existing wagons, between the laminated-spring buckle and the underframe, instead of the steel limiter, as shown in Fig. 5.

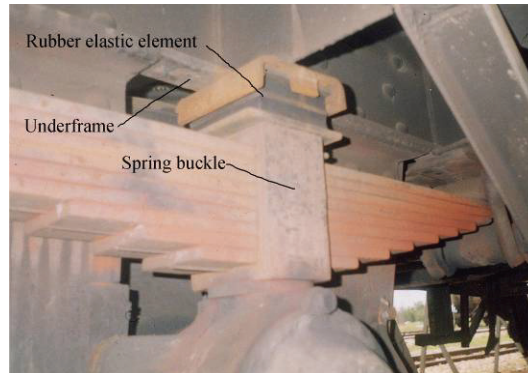

**Fig. 5** The rubber elastic element in the suspension system

The constructive solution of the rubber elastic element must be designed on the basis of free installing space in the suspension system. In order to determine the necessary characteristics of the rubber incorporated in the elastic element, the main aim is to find a compromise between the laminated spring relieving, the life time of the rubber elastic element, and dynamic characteristics of the whole wagon (number of occurrences and the values of the stress amplitudes – the deflection as a function of the traveled path). The diagram of the stiffness of the adopted rubber elastic element for the Fbd wagon obtained by the experimental way is shown in Fig. 6.

In the specific example of the Fbd wagon, the subsequent installation of the rubber elastic element causes a significant decrease of the stress amplitude, and therefore a new line of the operating stress of the laminated spring in the Goodman-Smith diagram (blue line 3 on Fig. 3).

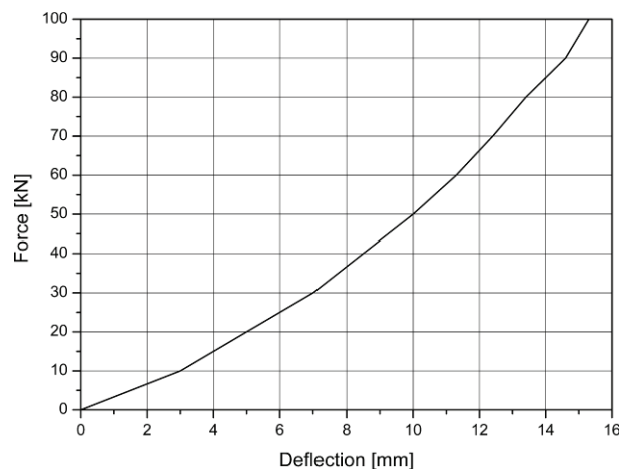

**Fig. 6** The diagram of the rubber element stiffness

This solution results in significantly lower stress amplitudes and hence it reduces the extent of fatigue loading. Therefore, blue line 3 on the Goodman-Smith diagram in Fig. 3 represents the compromise between the laminated spring relief and the rubber elastic element loading, which provides for permanent dynamic strength of the laminated spring.

#### 4. RESULTS OF THE INTRODUCED IMPROVEMENT

The testing of the suspension system with the rubber elastic element in exploitation is performed with the same measuring equipment and on the same track as previously performed tests without it. The change of the deflection of rubber elastic element  $z$  in the function of time for an empty and a laden wagon in exploitation conditions is shown in Fig. 7.

Based on the processing and analysis of the recorded signals of the suspension system elements' behavior, the projected improvement quality is assessed. The characteristic loads of the laminated spring with and without the rubber elastic element, in the static and dynamic conditions for laden wagon, are given in Table 1.

**Table 1** The effect of the introduced improvement

Force on LS	Without REE*	With REE*	Relieving of LS**
	[kN]	[kN]	[%]
Static $F_u^{st}$	119	61.42	48.4
Maximal dynamic $F_{max}^d$	157	68.06	56.6
Minimal dynamic $F_{min}^d$	125	53.45	57.3

\*REE – Rubber elastic element, \*\*LS – Laminated spring

From Table 1 it is evident that the total static force on laminated spring  $F_u^{st}$  of the fully laden wagon is lower for 48.4 %. This means that a part of the load is taken by the rubber elastic element, and in this way, even in the static conditions, the laminated spring is relieved for almost 50 %. As expected, this is even more expressed in the wagons running at dynamic loadings. The rubber elastic element has a parabolic curve of dependence of the force and the deflection and the percentage of the laminated spring relief in dynamic conditions is increased and ranges between 56.6 % and 57.3 %. During these tests, the maximal dynamic deflection of the rubber elastic element for the laden wagon is equal to  $z_{max}=12.2 \text{ mm}$  (Fig. 7).

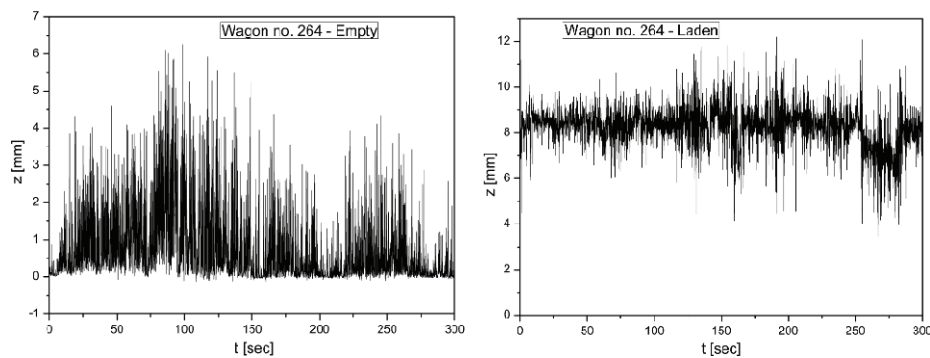

**Fig. 7** The rubber elastic element deflection

On the basis of the obtained results, the rubber elastic elements are installed on over 400 wagons for coal transportation at the thermal power plant "Nikola Tesla," Obrenovac. The number of fractures is reduced by more than 90 %.

## 5. CONCLUSION

The paper presents the failure analysis and the methodology for the improvement of the suspension system of the laminated-springs wagons. The technique is based on a specially designed rubber elastic element which can be subsequently installed in the wagons' suspension system. The element is very easy to install in the existing wagons, between the laminated-spring buckle and the underframe. The methodology for identifying the causes of unwanted fractures is focused on the theoretical and experimental analysis of the suspension system behavior with and without rubber elastic elements.

In the specific example of the Fbd wagon for coal transportation, the results of the introduced improvement are: the static load of the laminated-spring of a laden wagon is reduced by about 50 %; the dynamic load of the laminated spring of a laden wagon is reduced by over 60 %; in the eventual fracture of the main leaf of the laminated spring, the axle bearing does not remain unencumbered, which reduces the probability for the empty wagon's derailment; the number of fractures is reduced by more than 90 %, (it should be noted that the rubber elastic elements are installed in the existing suspension systems); the reliability of transportation of coal is increased, and thus, the overall reliability of the thermal power plant system.

In addition, the designed rubber elastic element satisfies the following requirements: it allows the suspension system behavior which provides for permanent dynamic strength of the laminated spring; it provides for the required dynamic characteristics of the wagon; and it prevents the occurrence of cracks and fractures on the underframe of a wagon.

Therefore, the consequent installation of the rubber elastic elements can prevent very frequent laminated springs' fractures and cracks on the underframes on the laminated-springs wagons. This can provide for enormously reduced costs of wagons' maintenance as well as for an increased efficiency of railway transportation.

## REFERENCES

13. Huichuan, F., Xiukun, W., Limin, J., Yong, Q., 2010, *Fault detection of railway vehicle suspension systems*, Computer Science and Education (ICCSE), 5th International Conference on Computer Science and Education, pp. 1264-1269.
14. Ding, X. J., Mei, T. X., 2008, *Fault Detection for Vehicle Suspensions Based on System Dynamic Interactions*, Proceedings of the UKACC International Conference on Control.
15. Xiukun Wei, Hai Lui, Yong Qin, 2011, *Fault isolation of rail vehicle suspension systems by using similarity measure*, 2011 IEEE International Conference on Service Operations and Logistics and Informatics (SOLI), pp. 391-396.
16. Hayashi Yusuke, Tsunashima Hitoshi, Marumo Yoshitaka, 2008, *Fault Detection of Railway Vehicle Suspension Systems Using Multiple-Model Approach*, Journal of Mechanical Systems for Transportation and Logistics Volume 1, Issue 1, pp. 88-99.
17. Kumbhalkar, M. A., Yenarkar, Y. L., Grover, A. K., 2011, *Failure Analysis of Inner Suspension Spring of Railway Engine: A Case Study*, Proc. of Int. Conf. on Advances in Robotic, Mechanical Engineering and Design 2011, pp. 12-16.
18. Petrović, Z. D., Bižić, B. M., 2012, *Improvement of suspension system of Fbd wagons for coal transportation*, Engineering Failure Analysis, 25, 89–96, doi.10.1016/j.engfailanal.2012.05.001.

## **POBOLJŠANJE SISTEMA OGIBLJENJA VAGONA SA GIBNJEVIMA**

**Dragan Petrović, Milan Bižić**

*Tokom eksploatacije teretnih vagona sa gibnjevima uočen je veliki broj lomova na elementima sistema ogibljenja. Ovi lomovi smanjuju efikasnost transporta i veoma često dovode do iskliznuća vagona sa velikim ekonomskim gubicima, a ponekad i sa ljudskim žrtvama. Ovaj rad prikazuje analizu otkaza i poboljšanje sistema ogibljenja vagona sa gibnjevima. Tehnika je bazirana na primeni specijalno projektovanog gumenog elastičnog elementa koji se može naknadno ugraditi u postojeći sistem ogibljenja vagona. Ovo rešenje je rezultat višegodišnjih istraživanja Centra za železnička vozila Mašinskog fakulteta Kraljevo u ovoj oblasti. Gumeni elastični element se veoma lako može instalirati u sve postojeće vagona, između opasača gibnja i donjeg postolja. Primenjena metodologija bazirana je na teorijskoj i eksperimentalnoj analizi ponašanja sistema ogibljenja sa i bez gumenog elastičnog elementa. Naknadna ugradnja gumenog elastičnog elementa omogućava sprečavanje veoma čestih lomova gibnjeva i elemenata donjeg postolja. Ovo omogućava enormno smanjenje troškova održavanja vagona i povećanje efikasnosti železničkog transporta.*

**Ključne reči:** poboljšanje, ogibljenje, vagon, gibanj