

Investigation of the transmission of fore and aft vibration through the human body

Miroslav Demić*, Jovanka Lukić

University of Kragujevac, Faculty of Mechanical Engineering in Kragujevac, Sestre Janjić 6, 34000 Kragujevac, Serbia

ARTICLE INFO

Article history:

Received 13 June 2007

Accepted 1 May 2008

Keywords:

Human

Fore and aft vibration

Partial coherence function

Transfer functions

ABSTRACT

Understanding the behavior of human body under the influence of vibration is of great importance for the optimal motor vehicle system design. Therefore, great efforts are being done in order to discover as many information about the influence of vibration on human body as possible. So far the references show that the major scientific attention has been paid to vertical vibration, although intensive research has been performed lately on the other sorts of excitation. In this paper, the results of the investigation of behavior of human body, in seated position, under the influence of random fore and aft vibration are shown. The investigation is performed by the use of an electro-hydraulic simulator, on a group of 30 healthy male occupants.

Experiments are performed in order to give results to improve human body modeling in driving conditions. Excitation amplitudes (1.75 and 2.25 m/s² rms) and seat backrest conditions (with and without inclination) were varied. Data results are analyzed by partial coherence and transfer functions. Analyses have been performed and results are given in detail.

The results obtained have shown that the human body under the influence of random excitations behaves as a non-linear system and its response depends on spatial position.

Obtained results give necessary data to define structure and parameters of human biodynamic model with respect to different excitation and seat backrest position.

© 2008 Elsevier Ltd. All rights reserved.

1. Introduction

Motor vehicle passengers and drivers are exposed to whole body vibration. Generally, vibration occurs simultaneously in all six axes. Variables, such as the vehicle type, vehicle speed, road surface and type of maneuver, can vary the magnitude and frequency content of vibration in each of the six directions. Some vehicles, such as tractors, trucks and tanks often show a greater magnitude of vibration in fore and aft direction than in vertical direction (Griffin, 1990; Mansfield and Lundström, 1999a,b). Experimental research and data analysis conducted (Lukić et al., 1999) on passenger vehicles showed that the highest vibration loading is in vertical and the lowest vibration loading is in lateral direction (Griffin, 1990; Holmlund and Lundström, 2001; Simić, 1970). For this reason, fore and aft vibration in vehicle environment cannot be neglected.

Describing the response of the seated human body exposed to vibration can be performed by seat to head transfer function (STHT). It represents a frequency dependent relation between acceleration of the head and acceleration at the seat to buttock interface. Beside

STHT, apparent mass and mechanical impedances can be used in order to predict seated human body behavior under fore and aft vibration. In the references reviewed, there is a very small number of papers which treat behavior of seated human body exposed to fore and aft vibrations (Holmlund and Lundström, 2001; Simić, 1970; Frolov et al., 1981; Mansfield and Lundström, 1999a,b; Corbridge and Griffin, 1989; Demić, 1984; Holmlund et al., 2000; Dupuis and Zerlett, 1984a,b; Qiu and Griffin, 2003; Rakheja et al., 2000; Paddan and Griffin, 1988), while the most papers treat vertical excitations (Griffin, 1990; Corbridge and Griffin, 1989; Fairley and Griffin, 1989; Demić, 1986; Osborne et al., 1981). Also, number of papers that treat human body behavior under fore and aft vibration with respect to STHT is insignificant. Bearing that in mind, this paper will consider seated human body behavior under broadband random fore and aft vibration.

Experiments are performed in order to get results to improve human body modeling in driving conditions. Excitation amplitudes (1.75 and 2.25 m/s² rms) and seat backrest conditions (with and without inclination) were varied. Experimental results were compared to results obtained in similar conditions in order to verify test procedure. Data results were analyzed and presented partially in Lukić, 2001; Lukić and Demić, 2002; Demić et al., 2002, so partial coherent and transfer functions' analysis have been performed and results will be given in detail.

* Corresponding author. Tel.: +381 34 330487; fax: +381 34 333192.

E-mail addresses: demic@kg.ac.yu (M. Demić), lukicj@kg.ac.yu (J. Lukić).

2. Experimental design

An electro-hydraulic motion simulator was used in subjective experiment. The simulator was designed to provide the test bandwidth from 0.3 to 30 Hz, but with very small (negligible) power for the frequencies over 20 Hz, with total loading mass of 200 kg, and to obtain vertical and horizontal random excitations simultaneously. In the performed experiment, only fore and aft random excitation is used. The investigators had to define frequency bandwidth and magnitude of excitation.

Data from accelerometers HBM B12/200 mounted on the seat pad, placed on seat buttock interface (S), head (H), platform (P) and steering wheel (W), in fore and aft (X) and vertical (Z) directions (Fig. 1), were recorded during experiment by the use of HBM DMC9012A amplifier and BEAM 3.1 acquisition data software and stored in data file afterwards.

Group of 30 trained, healthy male subjects (aged 43.9 ± 9.7 years, 180 ± 6.6 cm tall and 85.9 ± 14.1 kg mass) were exposed to fore and aft broadband random vibration. Bearing in mind the confident frequency domain of the simulator, the results of frequency contents lower than 0.5 Hz and above 18.5 Hz were neglected in the analysis.

In the experiment, subjects were sitting on the soft seat, in driving position, with hands on the steering wheel. The seat characteristics and the transfer function of platform-seat system were obtained with the seat loaded with a sandbag of total mass of 40 kg (Lukić, 2001). The seat was excited by one-directional random vibration in fore and aft direction. There is a resonant frequency of the platform seat system in fore and aft direction at approximately 22 Hz.

Since the seat was subjected to the influence of human body under random vibration, it was decided to perform investigations on the seat commonly used on local market. Seat cushion design was based on polyurethane, combined with springs.

Investigation of influence of proper choice of seat on vibration transmission through human body is briefly discussed in Simić, 1970 and conclusions were important for experimental posture. Variation of seat backrest angle was adopted, as well as usually used position in driving condition.

Seat backrest angle (position K inclined 14° with respect to vertical axis and position S in vertical position without inclination) and excitation magnitude (1.75 m/s^2 rms and 2.25 m/s^2 rms) were varied (Lukić, 2001; Demić et al., 2002; Lukić and Demić, 2002). Symbols $K_{1.75}$ and $S_{2.25}$ represent position of seat backrest angle (K or S) and the number in the subscript presents the amplitude of excitation.

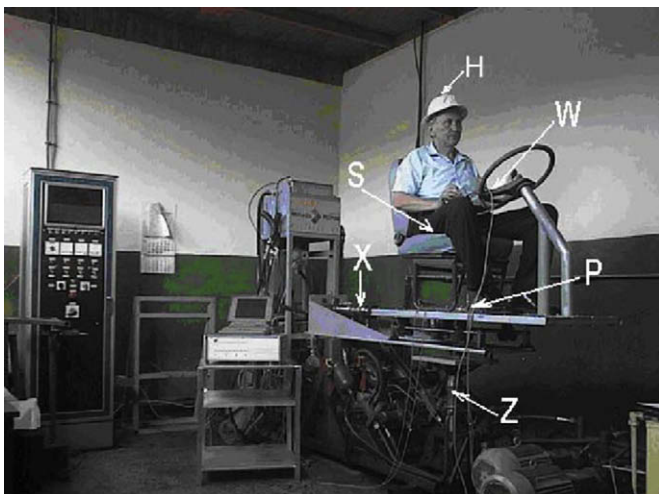

Fig. 1. Measurement equipment.

In order to determine SHTT function, accelerations were measured at the seat–buttock interface and on the head. Accelerometers were also mounted on plastic helmet.

Head vibration was registered by the use of plastic helmet, so it was necessary to analyze the errors induced by the relative motion between the head and the helmet. They are analyzed by the use of averaged plots of spectral density function of head helmet system, shown in Fig. 2. Acceleration data of head helmet system, given in Fig. 2, were measured under impulse excitation on one subject, repeated five times and then averaged. Subject is a member of the tested group.

It is obvious that the major errors take place at approximately 19 Hz, of resonance frequency, because, in that point, the spectral density magnitude is highest and this should be taken into consideration while analyzing the data in the frequency domain. To be more specific, amplitudes close to the frequency of 15 Hz will not be taken into consideration for further analyses.

For the illustration, Fig. 3 shows acceleration spectra of platform accelerations in X and Z directions and their ordinary coherence function under fore and aft broadband random excitation of 2.25 m/s^2 rms.

From Fig. 3, it is obvious that magnitude of fore and aft platform broadband random vibration is significantly higher than magnitude of platform signals in vertical direction. Platform was excited by a horizontal cylinder (X direction, Fig. 1) and the vertical vibration was a result of platform vibration. The elastic structure of platform, together with the influence of cylinder elastic suspension, caused accelerations in vertical direction. This was confirmed with a high level of coherence function, especially in frequency domain up to 15 Hz, and this influence cannot be neglected. Acceleration spectral density in vertical direction came from the structure characteristics. Shape of spectrum plots was influenced by characteristics of the shaker.

Test duration depends on lower and upper limiting frequencies, signal character, sort of data treatment, relative error, etc. There are known relations defining necessary test duration for FFT (Bendat, 1998; Bendat and Piersol, 1980; Bendat and Piersol, 2000). The existing recommendations in the literature are not ultimate, for instance ISO 2631/1 (1997) recommends that, in the case of FFT application by the use of filter and third-octave analysis of stationary signal, for frequencies above 0.5 Hz, test duration should be over approximately 227 s (error lower than 3 dB, reliability 90%). In case this recommendation is not fulfilled, the same standard requires a detailed description of data treatment procedure.

Having in mind that the aim of this paper was to confirm some facts related to human vibration under the influence of fore and aft

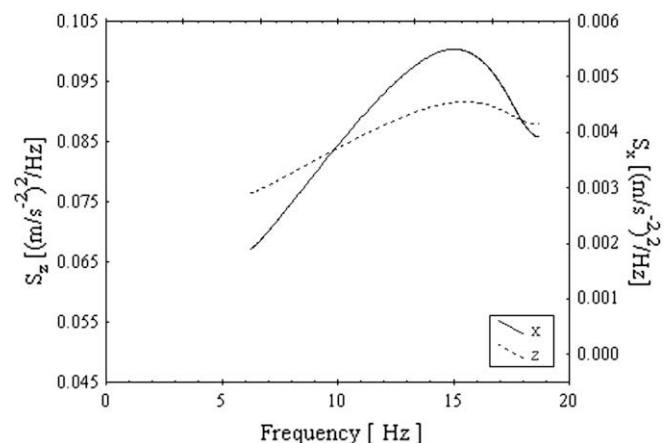

Fig. 2. Head helmet system characteristics.

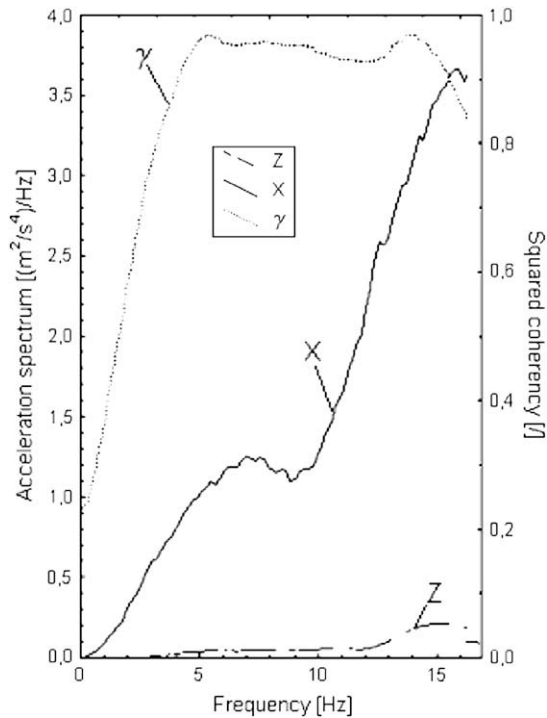

Fig. 3. Acceleration spectrums of platform in X and Z directions and their coherence function under fore and aft broadband random excitation of 2.25 m/s² rms.

vibration, it was found acceptable to perform FFT with constant frequency increment, instead of third-octave analysis. The analyses performed in Linden, 2003 have shown that the acceptable signal duration, for vehicles ride comfort investigation, is 1–2 min in the case of linear scale of frequency. Having that in mind, and recommendations from ISO 2631/1, 1997, the signal duration was 343.6 s.

This signal duration, with sampling frequency of 171.8 Hz provided the following (Bendat, 1998; Bendat and Piersol, 1980; Bendat and Piersol, 2000):

- Reliability of FFT above 0.0029 Hz estimated to be acceptable for the lower simulator excitation frequency of 0.3 Hz.
- With 512 averaging of spectra used in FFT, the random estimation errors of the following values were: for auto spectrum – 0.0454, for cross-spectrum – 0.057, and for coherence function – 0.032, which are acceptable, according to Bendat, 1998; Bendat and Piersol, 1980; Bendat and Piersol, 2000.

Based on these facts, it was found acceptable to apply the value of signal duration of 343.6 s for the analyses performed in the paper.

As it is known (Bendat, 1998; Bendat and Piersol, 1980; Bendat and Piersol, 2000), in frequency analyses, at frequencies above Nyquist frequency, there are magnitudes that can be copied to the area below Nyquist frequency and that could lead to wrong conclusions. In order to eliminate this effect, it is common to apply anti-aliasing filters (Bendat, 1998; Bendat and Piersol, 1980; Bendat and Piersol, 2000), preventing the occurrence of these errors. In this investigation, anti-aliasing filters were not used, because the spectral analyses have shown that above frequencies of approximately 20 Hz there are negligibly small amplitudes.

The preliminary analyses of the time history series have shown that they belong to a group of stationary random processes. It is known that the identification of parameters of random processes can be done in time, amplitude and frequency domain, which is thoroughly described in Bendat, 1998; Bendat and Piersol, 1980; Bendat and Piersol, 2000.

It should be pointed out, that data treatment in time domain is often based on the calculation of various types of mean values. The frequency domain analysis relies on auto spectra, cross-spectra, transfer functions, coherence calculation, etc. (Bendat, 1998; Bendat and Piersol, 1980; Bendat and Piersol, 2000).

Two specific softwares are developed to enable the analyses of the registered values, according to the procedures defined in Bendat, 1998; Bendat and Piersol, 1980; Bendat and Piersol, 2000:

- ANALSIGDEM (Demić, 2003a), is a software that enables the analysis of random stationary signals by calculating mean, minimal and maximal values, standard signal deviation, probability, probability density, joint probability density, auto-correlation and cross-correlation functions, correlation coefficients, auto spectra, and cross-spectra. The number of input data N is in 2^k form, where k is integer. In our analyses, the maximal value of N was 16,384 points.
- DEMPARCOH (Demić, 2003b) is a software that enables the identification of dynamic system characteristics with multiple input/multiple output option (up to 10 channels) by calculating ordinary, partial coherence and transfer functions. Since the establishment of ensembles by the use of data overlapping method is necessary for data averaging (Bendat, 1998; Bendat and Piersol, 1980; Bendat and Piersol, 2000), the number of input data in this software was defined with $2N$ (N is 2^k , where k is integer). In our investigation, N was 8192 points.

Because of the existence of intrasubjective and intersubjective variability of occupants' response (Griffin, 1990; Lukić, 2001; Demić et al., 2002), and in order to improve the test credibility, all the analyses were conducted for the averaged occupants responses in frequency domain. Correlation coefficients and statistical significance of measured acceleration are calculated and are given in Table 1.

By the use of software "ANALSIGDEM" rms values and standard deviation are calculated. Characteristic parameters of calculated values related to the occupant's time history ensemble are collectively given in Table 2. Acceleration signals were standardized with respect to gravity.

The analysis of the data from Table 2 leads to the following conclusions:

- The lowest value of rms and SD (standard deviation) is recorded for vertical head vibration, except in the case of seat backrest position, S, and 2.25 m/s² rms excitation, when the lowest value is for vertical seat vibration.
- The highest rms value is for vertical steering wheel vibration, except in the case of S seat backrest position and 2.25 m/s² rms excitation. In that case, the highest value is related to fore and aft platform vibration.
- The highest value of SD with K seat backrest position (for both excitations) is for vertical steering wheel vibration. In the case of S position and 1.75 m/s² rms excitation, the highest value

Table 1

Correlation coefficients and statistical significance of measured acceleration, $p = 0.005\%$, Kendall Tau.

	x_s	z_s	x_w	z_p	x_p	z_w	z_h	x_h
x_s	1.0000	-0.1423	-0.6408	-0.1151	-0.0461	0.0322	0.0845	-0.1397
z_s	-0.1423	1.0000	-0.0678	0.0437	0.0214	0.02135	-0.0805	0.3080
x_w	-0.6408	-0.0678	1.0000	0.0199	0.2741	-0.4183	0.0283	-0.4173
z_p	-0.1151	0.0437	0.0199	1.0000	0.0425	-0.0084	-0.0576	-0.0219
x_p	-0.0461	0.0214	0.2741	0.0425	1.0000	-0.0980	-0.0004	0.0201
z_w	0.0322	0.02135	-0.4183	-0.0084	-0.0980	1.0000	-0.0514	-0.5185
z_h	0.0845	-0.0805	0.0283	-0.0576	-0.0004	-0.0514	1.0000	-0.0493
x_h	-0.1397	0.3080	-0.4173	-0.0219	0.0201	-0.5185	-0.0493	1.0000

Table 2
Time history parameters series.

Seat backrest angle	Value	Rms [m/s ²]	Standard deviation, SD [m/s ²]	
K _{1.75} [m/s ²] rms	\ddot{x}_s	0.283	0.532	
	\ddot{z}_h	0.073	0.271	
	\ddot{x}_h	0.105	0.324	
	\ddot{z}_s	0.081	0.285	
	\ddot{x}_w	0.529	0.727	
	\ddot{z}_p	0.169	0.411	
	\ddot{x}_p	0.062	1.663	
	\ddot{z}_w	1.099	1.049	
	K _{2.25} [m/s ²] rms	\ddot{x}_s	0.182	0.427
		\ddot{z}_h	0.008	0.091
		\ddot{x}_h	0.133	0.364
		\ddot{z}_s	0.017	0.131
\ddot{x}_w		0.987	0.994	
\ddot{z}_p		0.211	0.459	
\ddot{x}_p		0.145	2.144	
\ddot{z}_w		1.580	1.570	
S _{1.75} [m/s ²] rms		\ddot{x}_s	0.207	0.55
		\ddot{z}_h	0.006	0.079
		\ddot{x}_h	0.192	0.439
		\ddot{z}_s	0.21	0.147
	\ddot{x}_w	0.528	0.727	
	\ddot{z}_p	0.169	0.411	
	\ddot{x}_p	0.062	1.835	
	\ddot{z}_w	1.099	1.049	
	S _{2.25} [m/s ²] rms	\ddot{x}_s	0.559	0.747
		\ddot{z}_h	0.058	0.241
		\ddot{x}_h	0.341	0.584
		\ddot{z}_s	0.055	0.235
\ddot{x}_w		0.147	3.804	
\ddot{z}_p		0.053	2.244	
\ddot{x}_p		0.945	2.325	
\ddot{z}_w		0.323	5.766	

was addressed to fore and aft platform vibration, and vertical steering wheel vibration for S position and 2.25 m/s² rms

Intention was to consider if there was any influence of seat backrest position on human body behavior. Boundary conditions with respect to seat backrest position were analyzed, so motions were not measured.

3. Theory of data analysis

Experimental results obtained are briefly analyzed and are given in Lukić, 2001; Demić et al., 2002, and here will be analyzed by partial coherent and transfer functions analysis. This method of data analysis was seldom used in the literature for human body vibration analyses before, and it gave very useful results in research of two axial random excitation of human body. Bearing that in mind, this method was used in this paper.

Analysis of vibration transmitted through human body showed that theory known from cybernetics (multiple input/multiple output systems) (Bendat, 1998; Bendat and Piersol, 1980; Bendat and Piersol, 2000) can be used. Head vibrations are output signals while all other measured signals should be treated as input signals (from steering wheel, seat, floor). This means that human body can be treated as a system with six input and two output signals (Bendat, 1998; Bendat and Piersol, 1980; Bendat and Piersol, 2000). Generally, output signals depend on input signal. There is an assumption in cybernetics theory that input signals decoupled between themselves, but it is not always the case, in real systems, for which special theory of signals' decoupling should be applied.

In Fig. 4, scheme of registered input and output vibratory signals affected on human is shown. Considered system with six inputs and two output signals (given in Fig. 4a) can be decoupled into two subsystems, with six inputs and one output, Fig. 4b and c.

The problem shown in Fig. 4a belongs to the group of problems called 'Multiple Input/Multiple Output Systems', and it may as well

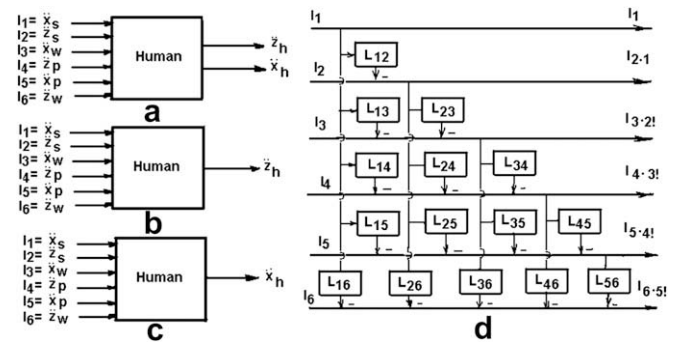

Fig. 4. Fourier transformation relationships for multiple input/multiple output model.

be regarded as a 'Multiple Input/Single Output Systems' (Bendat, 1998; Bendat and Piersol, 1980; Bendat and Piersol, 2000), as it is presented in Fig. 4a, b and c. It is obvious that each particular output variable may be observed as a function of input variables, which may be correlated.

Assuming that input variables are correlated, the problem of exclusion of mutual components from the input variables is schematically shown in Fig. 4d, where variables $L_{12}, L_{13}, L_{14}, L_{24}, L_{34}, L_{34}, L_{15}, L_{25}, L_{35}, L_{45}, L_{16}, L_{26}, L_{36}, L_{46}$ and L_{56} stand for complex values of the transfer functions between the corresponding input variables or their parts (Bendat, 1998; Bendat and Piersol, 1980; Bendat and Piersol, 2000).

In the case of the existence of correlation between particular input variables, and based on Fig. 4d, the expressions for independent (decoupled) input variables can be written:

$$\begin{aligned}
 I_{1!} &= I_1 \\
 I_{2.1!} &= I_2 - L_{1.2}I_1 \\
 I_{3.2!} &= I_3 - L_{1.3}I_1 - L_{2.3}I_{2.1!} \\
 I_{4.3!} &= I_4 - L_{1.4}I_1 - L_{2.4}I_{2.1!} - L_{3.4}I_{3.2!} \\
 I_{5.4!} &= I_5 - L_{15}I_1 - L_{25}I_{2.1!} - L_{35}I_{3.2!} - L_{45}I_{4.3!} \\
 I_{6.5!} &= I_6 - L_{16}I_1 - L_{26}I_{2.1!} - L_{36}I_{3.2!} - L_{46}I_{4.3!} - L_{56}I_{5.4!}
 \end{aligned} \tag{1}$$

Transfer functions between input signals, if they exist, are defined according to Bendat, 1998; Bendat and Piersol, 1980; Bendat and Piersol, 2000:

$$\begin{aligned}
 L_{12} &= \frac{I_2}{I_1}; L_{13} = \frac{I_3}{I_1}; L_{14} = \frac{I_4}{I_1}; L_{15} = \frac{I_5}{I_1}; L_{16} = \frac{I_6}{I_1}; \\
 L_{23} &= \frac{I_{3.1}}{I_{2.1}}; L_{24} = \frac{I_{4.1}}{I_{2.1}}; L_{25} = \frac{I_{5.1}}{I_{2.1}}; L_{35} = \frac{I_{5.2!}}{I_{3.2!}}; L_{45} = \frac{I_{5.3!}}{I_{4.3!}}; \\
 L_{26} &= \frac{I_{6.1}}{I_{2.1}}; L_{36} = \frac{I_{6.2!}}{I_{3.2!}}; L_{46} = \frac{I_{6.3!}}{I_{4.3!}}; L_{56} = \frac{I_{6.4!}}{I_{5.4!}};
 \end{aligned} \tag{2}$$

Partial coherence function, based on Eqs. (1) and (2), can be defined according to Bendat, 1998; Bendat and Piersol, 1980; Bendat and Piersol, 2000:

$$\gamma_{iy^*(i-1)!}^2 = \frac{|S_{iy^*(i-1)!}|^2}{S_{ii^*(i-1)!}S_{yy^*(i-1)!}} \tag{3}$$

where:

- $\gamma_{iy^*(i-1)!}^2$ is the partial coherence function between $i(t)$ input and $y(t)$ output when the linear effects of input $(i - 1)$ are removed from both $i(t)$ and $y(t)$ (for example, $\gamma_{2y.1!}^2$ is the partial coherence function between $x_2(t)$ and $y(t)$ when the linear effects of $x_1(t)$ are removed from both $x_2(t)$ and $y(t)$),
- $S_{iy^*(i-1)!}$ is conditioned cross-spectral density function between decoupled input signals and output signal,
- $S_{ii^*(i-1)!}$ is conditional auto spectral density function of input signals and

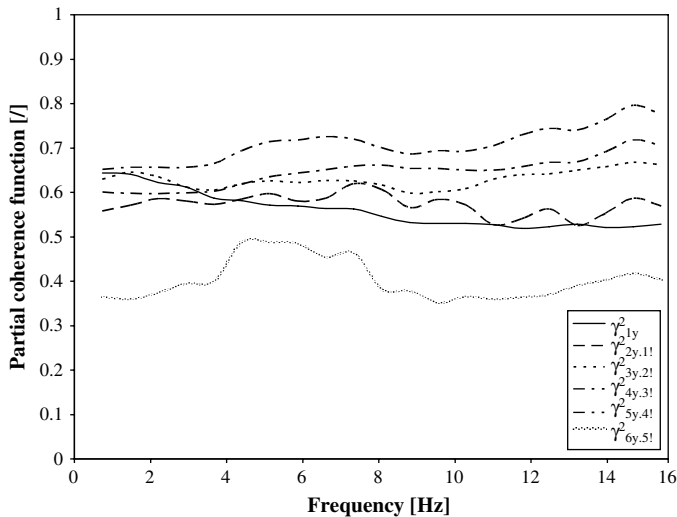

Fig. 5. Partial coherence functions (vertical direction – K_{1,75}).

- $S_{yy^{(i-1)}}$ is conditional auto spectral density function of output signals \dot{x}_h and \dot{z}_h , Fig. 4.

Based on expressions (1) and Fig. 4b and c, transfer function relations can be written based on decoupled input signals:

$$\begin{aligned} H_1 &= \frac{Y}{I_1}; H_{2,1} = \frac{Y}{I_{2,1}}; H_{3,2!} = \frac{Y}{I_{3,2!}} \\ H_{4,3!} &= \frac{Y}{I_{4,3!}}; H_{5,4!} = \frac{Y}{I_{5,4!}}; H_{6,5!} = \frac{Y}{I_{6,5!}} \end{aligned} \quad (4)$$

where Y represents vertical in the first case, and in the second case, fore and aft accelerations of the head.

Notation in expressions (1)–(4) and in Fig. 4 is adopted according to Bendat and Piersol, 1980, where indexes are: (1) acceleration of seat in fore and aft direction, (2) acceleration of seat in vertical direction, (3) acceleration of steering wheel in fore and aft direction, (4) acceleration of floor in vertical direction, (5) acceleration of floor in fore and aft direction and (6) acceleration of steering wheel in vertical direction. The same notation is used in all following figures.

All variables from expressions (1), (2) and (4) represent Fourier Transforms in complex form, while values defined by relation (3)

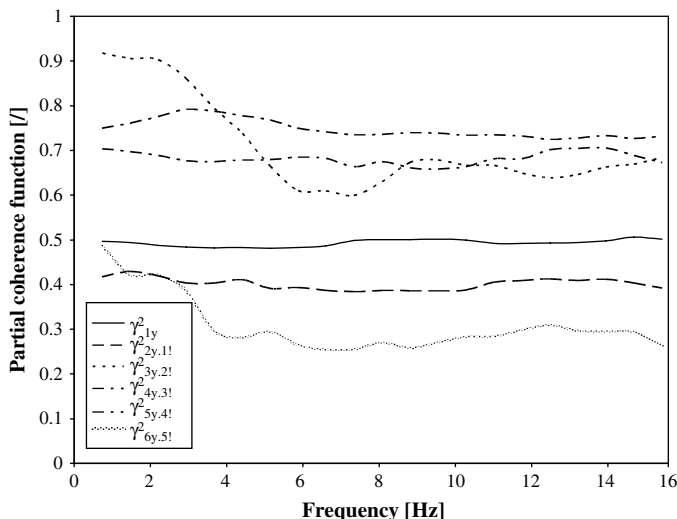

Fig. 6. Partial coherence functions (fore and aft direction – K_{2,25}).

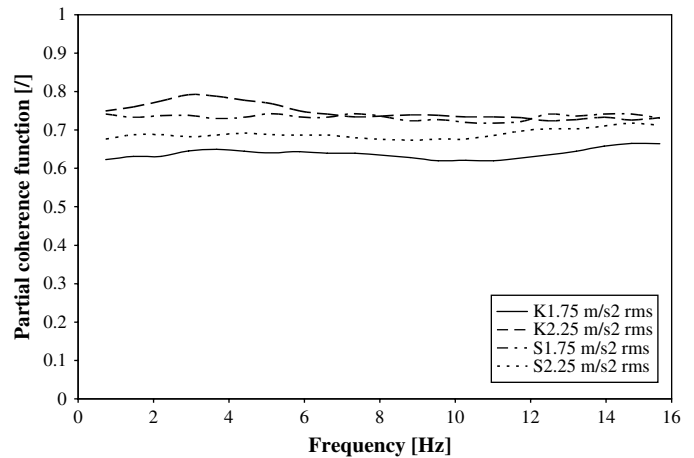

Fig. 7. Partial coherence function $\gamma_{4y,3!}^2$ in fore and aft direction.

are real numbers. The expression enables calculation of partial coherence and transfer functions, with necessary averaging of time and frequency realizations. Since the procedure of their calculation is thoroughly described in Bendat, 1998; Bendat and Piersol, 1980; Bendat and Piersol, 2000, it will not be repeated here. The method is realized by the use of DEMPARCHO software (Demić, 2003b). The application of the software enabled the calculation of partial coherence and transfer function between the observed output functions and calculated independent excitations acting on the human. Instead of complex modules of transfer functions were determined by expression (4).

Based on previously given statements two specific cases can be noticed:

- Input signals (fore and aft vibration of seat, vertical vibration of seat, fore and aft vibration of steering wheel, vertical vibration of floor, fore and aft vibration of floor and vertical vibration of steering wheel) with vertical vibration of a head as output signal and
- Input signals (fore and aft vibration of seat, vertical vibration of seat, fore and aft vibration of steering wheel, vertical vibration of floor, fore and aft vibration of floor and vertical vibration of steering wheel) with fore and aft vibration of a head as output.

4. Test results' analysis

Partial coherence functions are determined by the software and by the procedure given in Bendat, 1998; Bendat and Piersol, 1980; Bendat and Piersol, 2000 for all measured data and all inputs. Results are given partially in Figs. 5 and 6.

Analysis of all data and data partially given in Figs. 5 and 6 showed that there are influences of magnitude, frequency and seat backrest angle on values and characteristics of partial coherence functions. Influence is not unique in all considered cases. For instance, at conditions K_{1,75} and K_{2,25} the highest level of influence on partial coherence functions (depending on frequency) is in the case when linear effects of fore and aft and vertical seat vibrations, fore and aft steering wheel and fore and aft floor vibration are removed (except in K_{2,25} condition, fore and aft vibration). In other cases, the lowest influence has vertical vibration of steering wheel with linear effects of fore and aft and vertical seat vibration, fore and aft steering wheel vibration and fore and aft floor vibration removed. With respect to seat backrest angle in position S, situation is changed. Dominant input values are not emphasized as well as in K position.

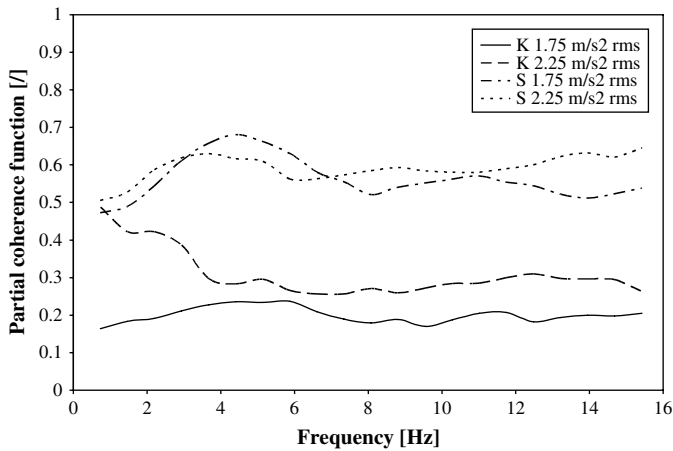

Fig. 8. Partial coherence function $\gamma_{6y,5}^2$ in fore and aft direction.

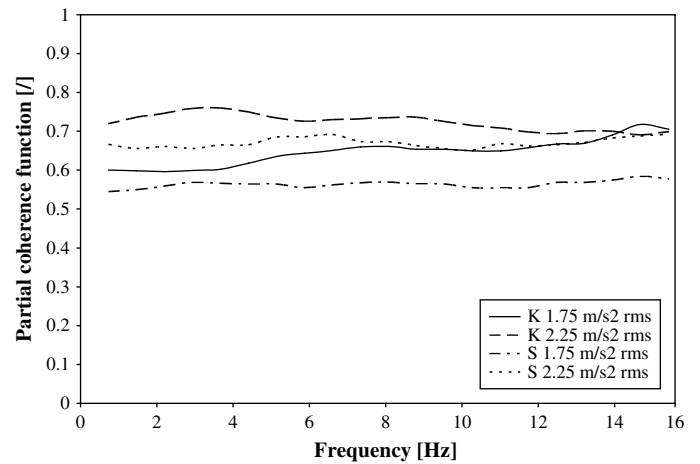

Fig. 10. Partial coherence function $\gamma_{4y,3}^2$ in vertical direction.

Partial coherence function values varied in domain 0.25–0.85. Influence of all input values on head vibration is not equal, and human body behaves as non-linear dynamic system. Partial coherence functions depend on seat backrest angle and on magnitude of excitation.

The increase in excitation magnitude caused the increase in partial coherence function values. Seat backrest angle in S position caused the increase in partial coherence function.

The lowest level of coherence function and the greatest data scatter are shown in Figs. 7–10. The influence of steering wheel can be neglected with respect to transmission of vibration through human body in sitting condition. The same can be concluded in the case of vertical direction.

Seat backrest in position S induced less magnitudes of partial coherence function in vertical direction than in K position.

Based on the previous analyses, especially the analysis of partial coherence functions, it was found beneficial to study dynamic parameters of human body. The application of the procedures from Bendat, 1998; Bendat and Piersol, 1980; Bendat and Piersol, 2000, specifying the calculation of transfer functions of multiple input/multiple output systems, based on the concept of constant parameter linear systems and the calculation of transfer functions of human body were performed (expression (4)), depending on the seat backrest position and rms of random excitation.

Software DEMPARCOH is upgraded and obtained calculations of transfer functions that are partially shown in Figs. 11–14.

Partial coherence functions enable the analysis of relation between output and decoupled inputs (Bendat, 1998; Bendat and Piersol, 1980; Bendat and Piersol, 2000), and they cannot be used for direct determination of system resonance. It is necessary to determine partial transfer functions, with decoupled inputs, that can be used to give qualitative assessment of vibration transmission through the human body, especially with respect to human body resonance.

Transfer functions showed inter subject variability. Analysis performed for averaged data for whole group of subjects in frequency domain up to 15 Hz is presented in Fig. 11.

In (Griffin, 1990; Simić, 1970; Frolov et al., 1981; Linden, 2003; Lukić, 2001; Demić et al., 2002; Wassermann, 1987; Demić, 1989) it is shown that it is important for further analysis to determine transfer function resonance of human body so they are given in Table 3.

In Figs. 12–14 six transfer functions are shown. They are determined according the expression (4). Magnitude of transfer functions $H_{2y,1}$, $H_{3y,2}$, $iH_{6y,5}$ are negligible and cannot be seen on figures in both directions. Magnitude of transfer functions in fore and aft direction are higher than magnitudes of transfer functions in vertical direction.

Based on the analysis of all data partially shown in Figs. 12–14 and human body resonance given in Table 3, the following conclusions can be drawn:

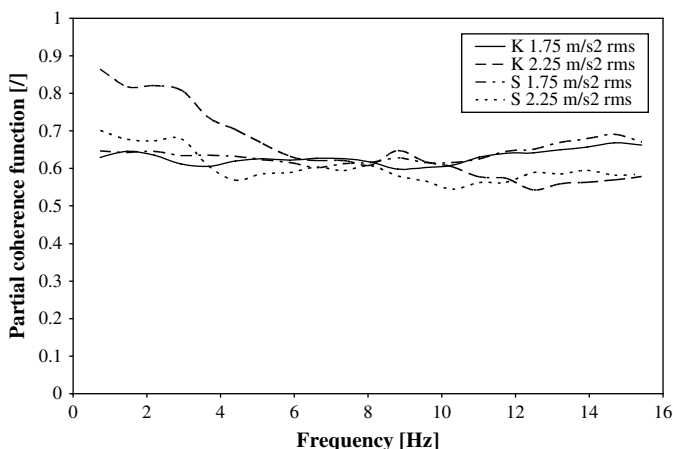

Fig. 9. Partial coherence function $\gamma_{3y,2}^2$ in vertical direction.

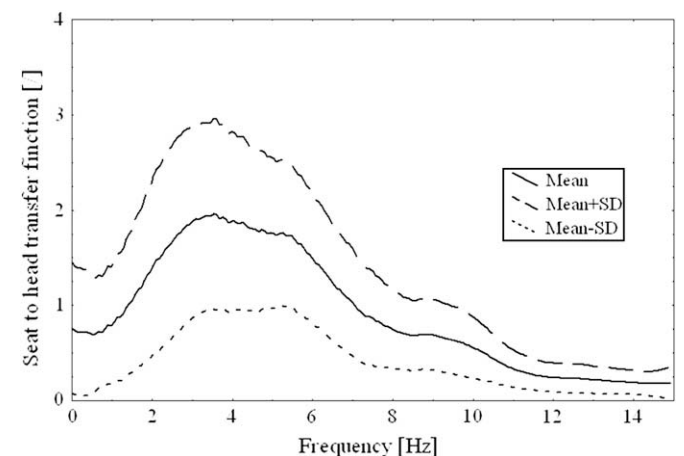

Fig. 11. Seat to head transfer function in fore and aft direction (seat backrest position K_{2,25}).

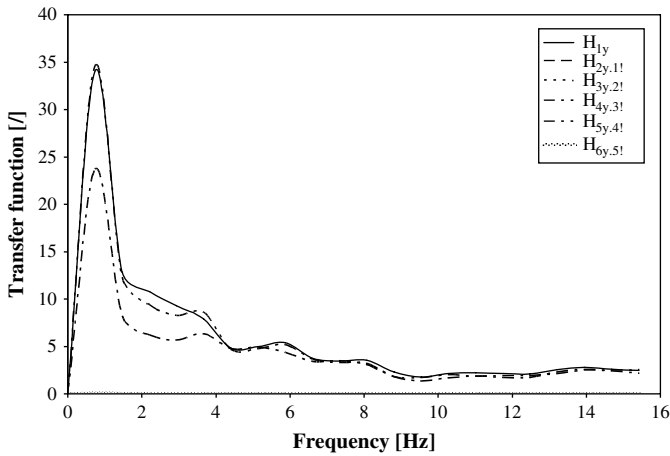

Fig. 12. Transfer functions (fore and aft direction $S_{2,25}$).

- Seat backrest position affects the human body transfer functions. Resonance and frequency response functions are changed.
- Seat backrest position affects the parameters of resonance (see Table 3).
- Excitation amplitude affects transfer functions and parameters of human body resonance points, which points out the fact that human body behaves like a non-linear system under the influence of fore and aft random vibration excitation.
- Analysis of transfer functions showed that vertical vibration of the seat, fore and aft, and vertical vibrations of the steering wheel do not provide the additional effect on vibration transmitted through human body
- The results obtained could be used for the synthesis of biodynamic vibration models of seated human body under the influence of random fore and aft vibration excitation.

5. Conclusions

On the basis of the performed investigations, the following can be concluded:

- Human body transmissibility characteristics depend on its spatial position. This should be taken into consideration in the synthesis of biodynamic vibration models of human body.
- Rms random vibration excitation affects human body transfer functions, which points out the fact that the human body behaves like a non-linear dynamic system.
- Seat backrest position affects the parameters of resonance.

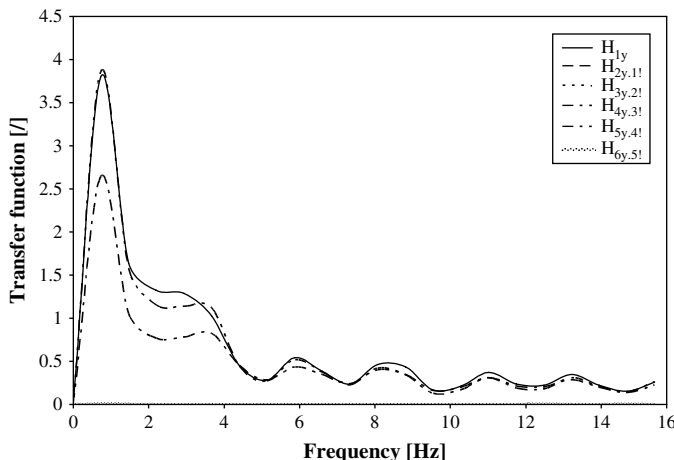

Fig. 13. Transfer functions (vertical direction – $S_{2,25}$).

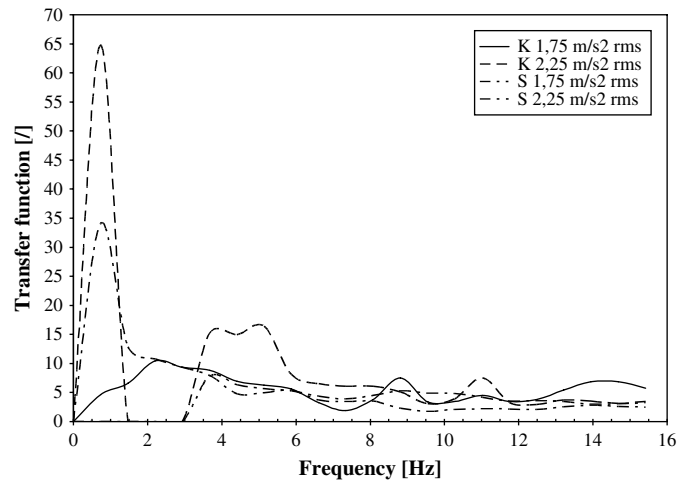

Fig. 14. The influence of seat backrest angle and excitation on transfer function H_{1y} .

Table 3

Parameters of human body resonance under fore and aft random excitation.

	H_{1y}		$H_{2y,1!}$		$H_{3y,2!}$		$H_{4y,3!}$		$H_{5y,4!}$		$H_{6y,5!}$	
	fr [Hz]	MM	fr [Hz]	MM	fr [Hz]	MM	fr [Hz]	MM	fr [Hz]	MM	fr [Hz]	MM
Fore and aft direction												
$K_{1,75[m/s^2]}$ rms	2.93	8.42	-	-	-	-	5.87	6.66	5.87	4.98	-	-
$K_{2,25[m/s^2]}$ rms	0.73	64.80	-	-	-	-	7.34	27.05	7.34	46.18	-	-
$S_{1,75[m/s^2]}$ rms	5.14	5.88	-	-	-	-	11.01	10.44	6.60	7.69	-	-
$S_{2,25[m/s^2]}$ rms	0.73	14.41	-	-	-	-	2.20	10.02	2.20	14.63	-	-
Vertical direction												
$K_{1,75[m/s^2]}$ rms	15.41	1.97	-	-	-	-	14.68	1.84	12.48	1.15	-	-
$K_{2,25[m/s^2]}$ rms	0.734	3.52	-	-	-	-	5.14	1.23	7.34	1.46	-	-
$S_{1,75[m/s^2]}$ rms	5.14	1.14	-	-	-	-	8.81	1.61	6.68	1.62	-	-
$S_{2,25[m/s^2]}$ rms	0.73	1.69	-	-	-	-	2.20	1.21	2.20	1.76	-	-

fr-resonant frequency, MM – maximal magnitude of the transfer function.

- Excitation amplitude affects transfer functions, partial coherence functions and parameters of human body resonance points, which points out the fact that human body behaves like a non-linear system under the influence of fore and aft random vibration excitation.
- On the basis of transfer functions of human under the influence of fore and aft vibration, it can be stated that parameters of resonance points depend on the position of seat backrest position and rms excitation, which is the characteristic for non-linear dynamic systems.
- In biodynamic model design phase, a model of passenger can be applied instead of a model of driver. Excitation of steering wheel has low influence on head vibration and it can be neglected.
- Obtained results give necessary data to define structure and parameters of human biodynamic model with respect to different excitation and seat backrest position.

Acknowledgement

This paper presents the results of research realized under patronage of the Research Centre of Serbian Academy of Sciences and Arts and University of Kragujevac, and financially supported by the Ministry of Science and Environmental Protection of the Republic of Serbia.

References

Bendat, J.S., 1998. Nonlinear Systems – Techniques and Applications. John Wiley and Sons.

- Bendat, J.S., Piersol, A.G., 1980. *Engineering Applications of Correlation and Spectral analysis*. John Wiley & Sons, New York.
- Bendat, J.S., Piersol, A.G., 2000. *Random Data – Analysis and Measurement Procedures*. John Wiley and Sons.
- Corbridge, C., Griffin, M.J., 1989. Vibration and comfort: vertical and lateral motion in the range 0.5–5.0 Hz. *Ergonomics* 29 (2), 249–272.
- Demić, M., 1984. Assessment of the effect of longitudinal and lateral vibration on human body fatigue using physiological approach. *Proceeding of the 108th Meeting of Acoustical Society of America, IMeCH 153/84*, Minneapolis.
- Demić, M., 1986. Physiological attitude towards influence of quasi random and repeated vertical shock vibration on human fatigue. *The Proceedings of the second International Conference on the combined effects of environments factors (ICCEF'86)*, Kanazawa.
- Demić, M., 1989. A contribution to identification of non-linear biodynamic oscillatory model of man, *International Journal of Vehicle Design*, 10 (2).
- Demić, M., 2003a. ANALSIGDEM: Software for signal analysis, Available from. www.ptt.yu/korisnici/i/m/imizm034/.
- Demić, M., 2003b. DEMPARCOH: Software for partial coherence function calculation, Available from. www.ptt.yu/korisnici/i/m/imizm034/.
- Demić, M., Lukić, J., Milić, Z., 2002. Some aspects of the investigation of random vibration influence on ride comfort. *Journal of sound and vibration* 253 (1), 109–129.
- Dupuis, H., Zerlett, G., 1984a. Beanspruchung des Menschen durch mechanische Schwingungen. Westkretz-Druckerei, Berlin-Bonn.
- Dupuis, H., Zerlett, G., 1984b. *Forschungsbericht Ganz-Koerper-Schwingungen*. Westreuz.
- Fairley, T.E., Griffin, M.J., 1989. The apparent mass of the seated human body: vertical vibration. *Journal of Biomechanics* 22, 81–94.
- Frolov, et al., 1981. *Protection against vibration and impact (in Russian)*. Mashinostroenie, Moscow.
- Griffin, M.J., 1990. *Handbook of Human Vibration*. Academic Press, London.
- Holmlund, P., Lundström, R., 2001. Mechanical impedance of the sitting human body in single-axis compared to multi-axis whole body vibration exposure. *Clinical Biomechanics* 16 (S1), 101–110.
- Holmlund, P., Lundström, R., Lindberg, L., 2000. Mechanical impedance of the human body in the horizontal direction. *Journal of Sound and Vibration* 215 (4), 801–812.
- International Standardization Organization ISO 2631/1, 1997. *Guide for the Evaluation of Human Exposure to Whole Body Vibration*.
- Linden, J., 2003. *Test Methods for Ride Comfort Evaluation of Truck Seats*, a Master Thesis, Royal institute of Technology, Stockholm.
- Lukić, J., 2001. *Ride comfort parameter identification of passenger cars*, Ph.D. Thesis, University of Kragujevac, Faculty of Mechanical engineering, Kragujevac.
- Lukić, J., Demić M., Spentzas, K., 1999. Determination of dominant ride loading of passengers. *Proceedings of third International Symposium on Advanced Electromechanical Motion Systems*, Patras, Greece.
- Lukić, J., Demić, M., 2002. Seated human body behavior under random vibration. *Proceedings of the 2002 IBEC and ATT Conferences on CD-ROM-01 – 2059*.
- Mansfield, N.J., Lundström, R., 1999a. The apparent mass of the human body exposed to non-orthogonal horizontal vibration. *Journal of Biomechanics* 32 (12), 1269–1278.
- Mansfield, N.J., Lundström, R., 1999b. Models of apparent mass of the seated human body exposed to horizontal whole-body vibration, aviation. *Space and Environmental Medicine* 70 (No.12).
- Osborne, D.J., Heath, T.O., Boarer, T.O., 1981. Vibration in human response to whole body vibration. *Ergonomics* 24 (4), 301–313.
- Paddan, G.S., Griffin, M.J., 1988. The transmission of translational seat vibration to the head – II. Horizontal seat vibration. *Journal of Biomechanics* 21 (No 3), 199–206.
- Qiu, Y., Griffin, M.J., 2003. Transmission of fore and aft to a car seat using field tests and laboratory simulation. *Journal of sound and vibration* 264, 135–155.
- Rakheja, S., Boileau, P.E., Stiharu, I., 2000. Seated occupant apparent mass characteristics under automobile postures and vertical vibrations. *The second International conference on vibration injuries*, Siena, Italy.
- Simić, D., 1970. *Beitrag zur Optimierung der Schwingungseigenschaften des Fahrzeuges Psychologische Grundlagen des Schwingungskomfort*, Doctor Dissertation, TU Berlin.
- Wassermann, D.E., 1987. *Human Aspect of Occupational Vibration*. Elsevier.