

Load of Remote Controlled Battle Station Upper Carriage with Integrated Automatic Grenade Launcher

Milan Ivković¹⁾
Vladimir Milovanović¹⁾
Bogdan Nedić¹⁾
Stefan Đurić¹⁾

The paper presents a numerical analysis, using the finite element method, for the case of static and dynamic loading of the upper carriage of the remote-controlled combat station, due to the recoil force generated by the operation of the integrated automatic grenade launcher 30mm M93. The paper describes the problem of integrating the BGA 30mm M93 automatic grenade launcher onto the combat platform, and based on the dimensions of the automatic launcher, modeling of the automatic launcher stand with cradle was carried out. As a result of the weapon dynamics equations and internal ballistics calculations, the pressure force of the gunpowder gases and the recoil force of the automatic grenade launcher were calculated. The paper also presents the results of the dynamic analysis of the finite element model of the upper gun carriage loaded with the obtained impulse recoil force for different elevation angles of the weapon.

Key words: Remote weapon station, finite element analysis, recoil force, carriage construction

Introduction

THE development of new weapons follows its adequate way of integration into the combat platform in order to achieve the greatest possible tactical mobility, and the possibility of occupying the best possible position in relation to the target.

Modern tendencies and strategies of warfare exclude conventional methods and strategies of warfare. The actions of the armies in the war zones were reduced to the minimum necessary weapons resources and the number of engaged military personnel. One of the increasingly present models of battlefield modernization is reflected in the frequent use of remote combat stations and more advanced equipment for observing and detecting targets. Modern constructions of remotely controlled combat stations consist of weapons with a combat kit, stabilizing weapons cradle, fire control systems, opto-electronic observation and aiming systems coupled with the gun barrel.

Today's current military operations show the need for fire protection of lightly armored vehicles during hostilities and during the logistical delivery of equipment on the battlefield. For the above reasons, in order to improve the combat capabilities of light and medium combat vehicles in the world, as well as in our country, a program for the development of light remotely controlled combat stations (RWS) was launched.

One of the main prerequisites for the integration and successful use of this type of combat systems is the achieved precision and accuracy of shooting with as little dispersion of hits on the given line of fire as possible, which is largely influenced by the design of the combat platform.

This paper deals with the development and analysis of a remote controlled weapon station model with the integrated of

the domestic automatic grenade launcher BGA 30 mm M93.

Construction of combat platform upper carriage

This paper analyzes the integration of the automatic grenade launcher BGA 30 mm M93 on a light combat platform, and the final appearance of such a system depends on the dimensions of the weapon, the method of installation, the type of movement, the degree of armor protection and other characteristics that are conditioned by the tactical and technical requirements that the system should satisfy.

Combat platforms are light constructions and usually consist of upper carriages of different shapes with a pivot and a cradle in which mainly machine guns, automatic cannons and automatic grenade launchers are fixed [1]. During the firing action, the loads and moments caused by the recoil force of the weapon, as well as the weight of the oscillating mass, are transferred from the weapon cradle to the upper carriage from the integrated weapon system. The forces transmitted to the gun carriage are significantly less than the pressure force of the powder gases generated in the barrel of the weapon during shooting. In the case of direct integration of the weapon, without spring shock absorbers, the forces acting on the carriage assembly can be neutralized by the forces of the deformation work of the elastic base, which is sufficiently resistant and rigid to meet the structural requirements.

The demands placed on the construction of the carriage of the combat station are the satisfaction of the conditions of stability of the system against overturning, resistance to all loads in a static and dynamic sense caused by alternating shock loads when firing weapons and reduction of forced oscillations that can affect the accuracy of shooting and

scattering of hits.

Based on the known structural parameters of the automatic grenade launcher BGA 30 mm M93, table 1, the goal is to calculate the forces and loads acting on the entire assembly of the automatic launcher, which are transferred to the structure of the upper carriage of the platform by the cradle.

Table 1. Construction parameters of automatic grenade launcher BGA 30 mm M93 [1]

Weapon data	BGA 30mm M93
Mass of empty weapons	35kg
Mass of grenade	0,360kg
Mass of bolt	4,3kg
Barrel length	300mm
Weapon length	825mm
Effective range	1700m
The initial projectile velocity at the mouth of the barrel	185m/s
Maximum pressure of powder gases in the barrel	150MPa

Based on the geometric dependence of the positions of the arms cradle supports, the center of gravity of the weapon, the axis of the barrel channel (the place where the force of the gunpowder gases acts) and the position of the pivot, a schematic representation of the forces given in Fig.1 was created. For these conditions, the equations of stability and loading of the upper carriage are derived.

During the firing action, the gun carriage is loaded with a recoil force, R, at an elevation angle, a, by the weight of the system, G, and at the place where the is pivot , reactions of connections Fa and Fb occur . From the conditions of the balance of forces in the system, we obtain the reactions on analytical way, which we will be confirmed with numerical analysis.

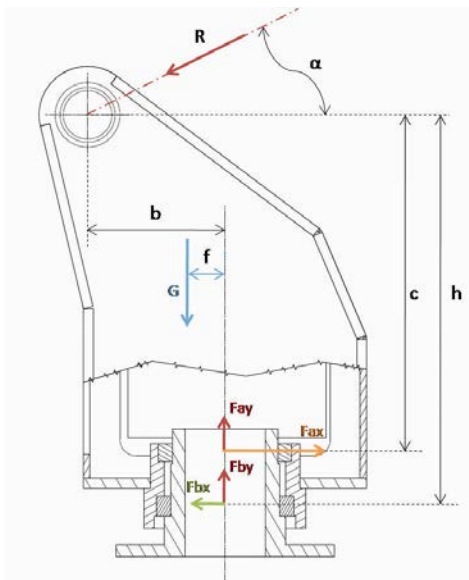

Figure 1. Schematic representation of the forces acting on the upper carriage during firing

Integrated weapon

The BGA 30 mm M93 works on the blowback principle, it belongs to the group of automatic weapons that use bolt recoil for operation. With such systems, the barrel is immobile, and the bolt is not locked to the barrel or the box during firing, so the system with the so-called by free recoil bolt [2].

The ammunition of automatic grenade launchers in the

internal ballistic sense uses the principle of a high and low pressure chamber [3].

The force that causes the tension of the carriage actually represents the recoil force of the entire weapon and is equal to the braking force of the bolt, R. During firing, powder gases are created behind the projectile and a certain amount of energy is spent partly on projectile motion and partly on the recoil of weapon parts. The pressure force of the created powder gases propels the projectile and acts on the walls of the barrel and the bottom of the shell, and thus on the face of the bolt, tending to move it backwards. This force Pkn[N] is calculated through the pressure p [bar] acting behind the projectile, obtained as a result of internal ballistic calculations [4].

In the automatic grenade launcher 30 mm M93, during firing, the bolt movement is opposed by the friction force on the contact surfaces of the moving parts (about 5%), the resistance force of the return springs (about 15%) and the hydraulic resistance force (about 80%) which together constitute the resistance force R [1]:

$$R = E_{tr} + 2F_{op} + F_{hk} - m_t g \sin \alpha \quad (1)$$

The last part in equation (4.2.4) refers to the weight component of the recoil mass, which, when the barrel of the weapon is elevated by an angle a, reduces the effect of the recoil resistance force.

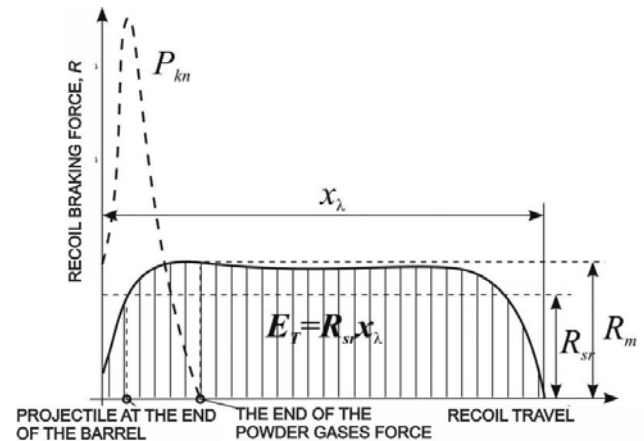

Figure 2. Diagram of recoil braking force []

Bolt braking mechanisms have the role of transforming a short-term, but large impulse of recoil force IT into a long-term impulse of resistance force IR, which is significantly smaller. Fig.2 shows a graphical representation of the transformation diagram of the braking force.

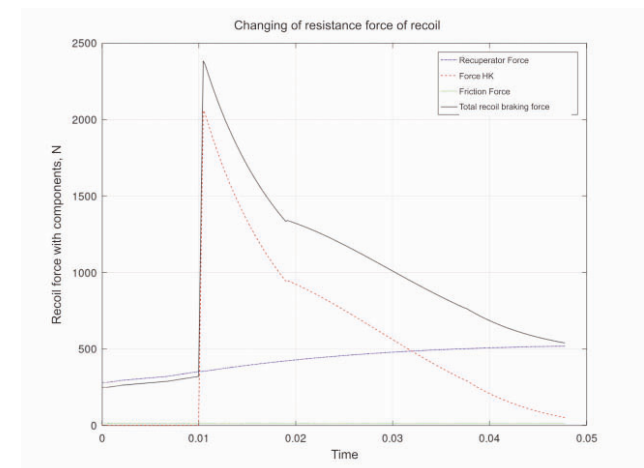

Figure 3. Components of the recoil resistance force and the total recoil resistance force [6]

In the OCTAVE program, a software solution was created that calculates the forces of resistance to the movement of the shutter in the course of time and the distance traveled and provides graphical representations of all the calculated functions. [5,6]

The total resistance force, whose graph and values are given in Fig.3, includes previously defined components - friction force, spring resistance force and hydraulic brake resistance force. The largest share, and therefore the influence on the law of change of force R , has the resistance force of the hydraulic brake.

A calculated resultant recoil resistance force R is transmitted to the platform, creating forced oscillations of the system. When the force becomes equal to zero, the system continues to move, which has the character of damped self-oscillations, until it stops completely in the equilibrium position. [7,8]

Battle station upper carriage model and numerical load analysis

The CAD model of the battle station integration platform for operational purposes was created in the CATIA V5 R21 software package [22]. The model represents a simplified version of the combat platform designed according to industry requirements. For the sake of simpler small-scale production, it is planned to manufacture the assembly of the upper carriage using the technology of welding sheets and plates of different thicknesses. Based on the CAD model, the positions of the barrel axis, the appearance of the upper carriage, as well as the masses of the cradle and the upper carriage were obtained.

The finite element model was created with by the of the mid-surfaces model based on the existing geometry in the FEMAP software package.

In order to satisfy the basic principles of the finite element method based on continuum mechanics, with the use of available tools in the software, the existing model was simplified, and the weld zones were approximated by transitional zones and continuous joints at the welding points of the central part and sides of the carriage, Fig.4 [9]. At the same time, care was taken to ensure that the dimensions of the models remain unchanged.

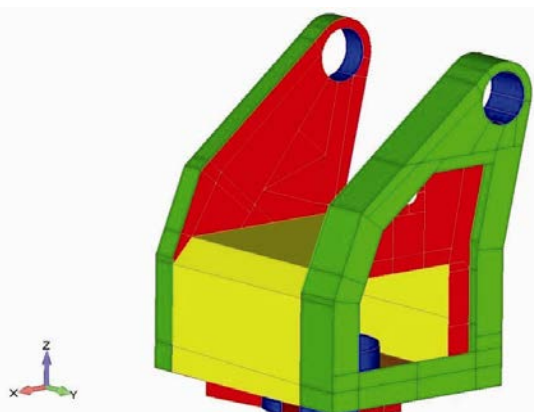

Figure 4. Display of the model of the middle surfaces of the structure of the upper carriage in the software package FEMAP.

The creation of a finite element mesh is the most important item of structural analysis, because the geometric and material properties of the structure are transferred through it. For the elements of the supporting structure of the upper carriage, 2D finite elements generated on the midsurface geometry were chosen and given the properties of shell elements (plates) that

represent the thin-walled construction created by bending and welding the corresponding plates and sheets [10,11]. The layout of the generated finite element mesh is shown in Fig.5.

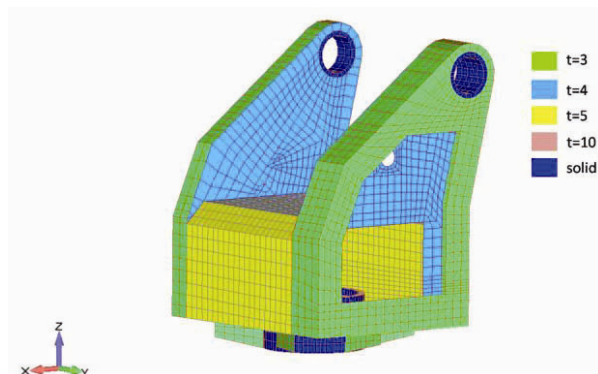

Figure 5. MKE upper carriage construction model

In order to check the model and match the analytical model with the numerical one, an analysis was performed for the case of static loading, where the model was loaded with the maximum recoil force of the weapon, which is 240 dN. In the case of dynamic analysis, a load of variable force as a function of time, $f(t)$, is given, which is obtained as a result of the weapon's dynamics.

As part of the dynamic analysis of the loading of the upper carriage by impulse recoil force for different elevation angles, 400 output sets of solutions were obtained for each analysis. The total simulated time represents an interval of 0.2s during which the gun carriage is loaded with an impulse recoil force and during which the maximum stresses appear as a response of the construction before the system calms down. Eight analyzes were performed for a range of elevation angles from -10° to 60° with an arithmetic difference of 10° .

The most important quantities that were analyzed within the work are displacements and stresses that occur in the critical zones of the structure for different elevation angles, that is, the directions of dynamic load actions.

Results of the analysis

For the set analysis parameters and the generated finite element model, results were obtained for the effective (Von-Mises) stress fields of the upper carriage model under the action of dynamic load at different elevation angles α . Based on the load analysis of the upper carriage for different elevation angles, the changes in the values of the maximum stresses and deformations in the zones of the most loaded elements of the structure were monitored and were shown graphically depending on the time of the dynamic load (weapon firing) and the elevation angle.

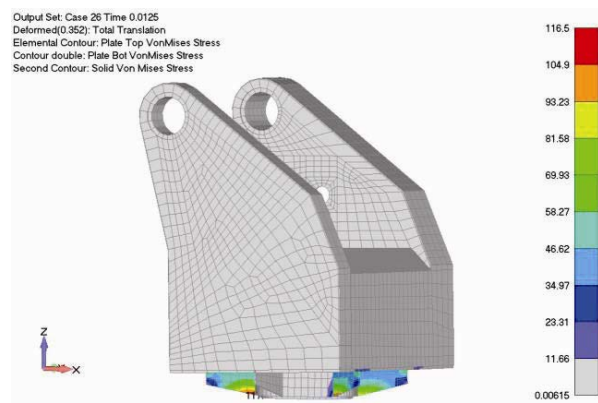

Figure 6. The effective (Von-Mises) stress field of the upper carriage for the

elevation angle ($\alpha = 20^\circ$), moment 0.0125s

The effective stress field chosen for the critical case of loading the upper carriage, elevation angle ($\alpha = 20^\circ$), is shown in Fig.6, where the maximum value of the stress, when the load is applied, is 116.5 MPa, while 7.

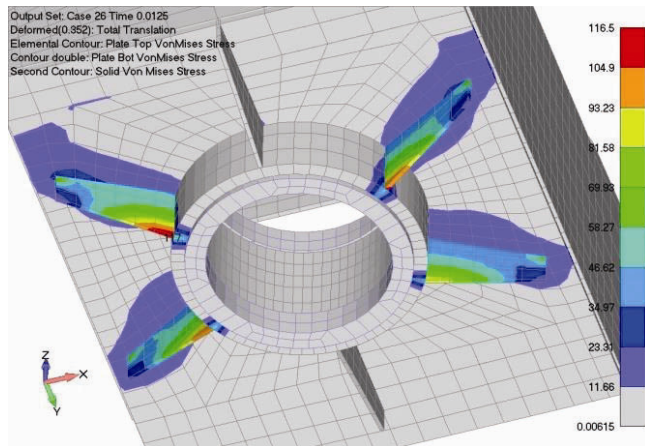

Figure 7. Place of maximum (Von-Mises) stress of upper carriage for elevation angle ($\alpha = 20^\circ$), moment 0.0125s

The field of total displacements of the upper carriage model under the action of dynamic load at the elevation angle ($\alpha = 20^\circ$) is shown in Fig.8. From the displayed image and the palette for displacement values, it can be seen that the total displacement that occurs during the action of the recoil force is 0.352mm

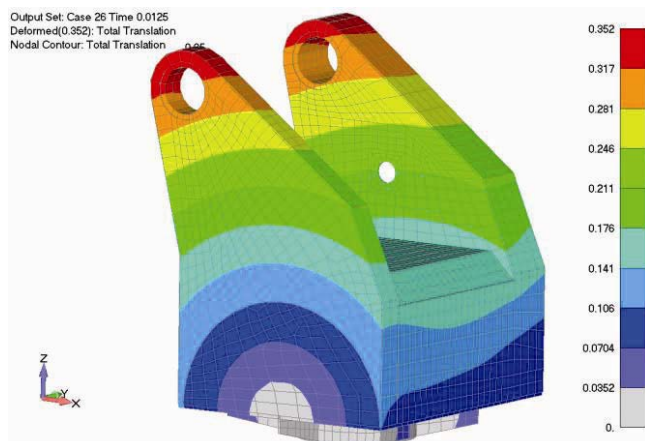

Figure 8. Display of the field of total displacements for an elevation angle of 20° , time instant of 0.0125s

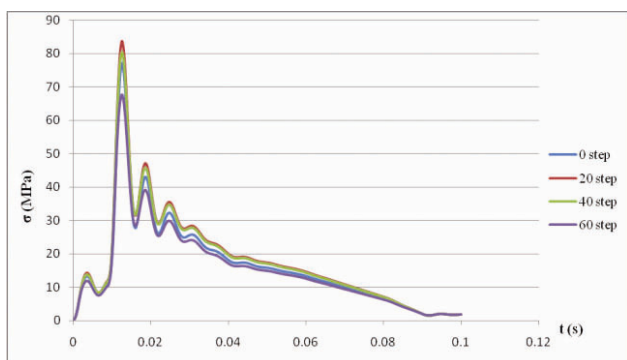

Figure 9. Graphic representation of the effective stress for the rib element of the structure depending on the time interval for different elevation angles.

Fig.9 shows a graphic representation of the increase in the stress of the construction, in the zone of the most loaded element, depending on the time interval of the dynamic load

for different elevation angles. From the picture, you can see the trend of increasing load for elevation angles from -10° to 60° and the time of settling down of the forced oscillations of the entire platform caused by the dynamic effect of the recoil force of the automatic grenade launcher. It is also possible to observe the moment of action of the maximum stresses and displacement of the construction, an interval of 0.0125s.

Conclusion

In the framework of the paper, the results of the analysis of the loading of the upper carriage during a simulated single fire from an integrated weapon were given, and the values of the effective stresses and total displacements for the loaded configurations were presented. Based on the numerical analysis of the dynamic loading of the upper carriage by the force of recoil, the most loaded parts of the upper carriage were observed.

Through this work, experience was gained for further improvement and optimization of the combat station system. The recoil force can be further reduced by placing the automatic grenade launcher on a stand with spring shock absorbers, which would further reduce weapon oscillations and increase accuracy.

The practicality of this method is its predictive capabilities, where based on the numerical analysis, using the finite element method, the dynamic loading of the structure of the upper carriage of the remotely controlled combat station and the processing of the results of the analysis for the case of burst fire, the possibility of predicting the maximum number of firings from the integrated weapon due to which there will be no stress increase above the critical value for the given construction material. Applying these methods would reduce the resources necessary for the development of a new system and reduce the number of tested models in order to confirm the validity of the construction.

Literatura

- [1] Aleksandar Kari: Daljinski upravljive borbene stanice, Materijal za predavanje iz predmeta integracija naoružanja na mobilne platforme, 2017
- [2] Uputstvo za korišćenje i održavanje - 30 mm bacač granata automatski, Zastava oružje.
- [3] JARAMAZ, S., MICKOVIĆ, D.: Primena principa komore visokog/niskog pritiska na optimizaciju pogona municije za automatski bacač granata, Mašinski fakultet, Beograd, 2001.
- [4] M. Petrović, Mehanika automatskog oružja, Vojnoizdavački zavod, Beograd, 2009.
- [5] Ljubiša Tančić: Unutrašnje balističko projektovanje, Beograd 2014. god.
- [6] Nina Živanović, Aleksandar Kari: behaviour simulation of light mobile platform under the influence of integrated weapon's recoil force, OTEH, Beograd 2018. god.
- [7] Zoran Ristić: Konstrukcija automatskog naoružanja, skripta Bg. - Kg. 2014. god.
- [8] M. Kalezić, Projektovanje artiljerijskih sistema, Knjiga JEDAN, Beograd, 2010.
- [9] KOJIĆ, M., SLAVKOVIĆ, R., ŽIVKOVIĆ, M., GRUJOVIĆ, N.: Metod konačnih elemenata I, Mašinski fakultet, Kragujevac, 1998. - pristupljeno 16.9.2021. godine
- [10] ŽIVKOVIĆ, M.: Nelinearna analiza konstrukcija, Mašinski fakultet, Kragujevac, 2006.
- [11] ŽIVKOVIĆ, M., VULOVIĆ, S.: nonlinear static and dynamic structural analysis, Kragujevac, 2013.

Received: 22.07.2022.

Accepted: 12.09.2022.

Opterećenje gornjeg lafeta daljinski upravljane borbene stanice sa integrisanim automatskim bacačem granata

Radom je prikazana numerička analiza, metodom konačnih elemenata, za slučaj statičkog i dinamičkog opterećenja gornjeg lafeta, daljinski upravljane borbene stanice, silom trzanja nastale radom integrisanog automatskog bacača granata 30mm M93. U radu je opisan problem integracije automatskog bacaca granata BGA 30mm M93 na borbenu platformu i na osnovu dimenzija automatskog bacača sprovedeno je modeliranje postolja automatskog bacaca sa kolevkom. Kao rezultat jednačina dinamike naoružanja i unutrašnje balističkih proračuna izračunata je sila pritiska bartunih gasova i sila trzanja automatskog bacača granata. Radom su takode prikazani rezultati dinamičke analize modela konačnih elemenata gornjeg lafeta opterećenog dobijenom impulsnom sila trzanja za različite uglove elevacije oružja

Ključne reči: Daljinski upravljana borbena stanica, analiza konačnih elemenata, sila trzanja, konstrukcija gornjeg lafeta