

SOUND INSULATION OF A MECHANICAL WORKSHOP

Zoran Petrović¹, Branko Radičević¹, Milan Kolarević¹, Vladan Grković¹

¹ University of Kragujevac, Faculty of Mechanical and Civil Engineering Kraljevo, Serbia, petrovic.z@mfkv.kg.ac.rs

Abstract - The paper presents a design process related to sound insulation of a small mechanical workshop for storing eccentric presses, which is located in a densely populated housing estate. Starting from the theoretical model of acoustic insulation power of a single solid partition, a complex partition and a multi-layer partition, the acoustic insulation power of the walls and the ceiling in the workshop was determined. The results of calculation of workshop isolation coincide to a great extent with the experimental results of measuring noise levels.

Keywords: noise, mechanical workshop, sound insulation

1. INTRODUCTION

Small production workshops are often located in business-residential zones. Analysis of their impact on the environment implies that they must fulfil certain noise requirements. Noise sources must not generate noise levels whose rating level exceeds limit values of noise indicators in the environment.

The paper is based on the request for designing acoustic protection of a workshop for storing two eccentric presses. The future workshop should be part of a business facility in a densely populated housing estate, where the façade of the next door neighbour is only 5 m away. The tendency was to organise the entire production process at one location because the production of parts on the eccentric presses had been dislocated due to the problem with noise. Such a manner of production had led to increased costs of production. Based on the preliminary design of sound insulation of the new workshop, the owner decided to invest some funds in sound insulation and consolidate the production process.

The acoustic quality of a building defined by a project task or only by corresponding standards is obligatorily controlled during its technical acceptance after the completion of construction. The basic standard in the field of acoustics in civil engineering, SRPS U.J6.201, defines the obligation of checking acoustic quality of buildings during their technical acceptance.

2. NOISE SOURCES

The eccentric press is a machine for deforming, in which the operating stroke of the eccentric press is accomplished through the eccentric which converts the circular motion of the drive shaft into the rectilinear motion of the tool. In the workshop, there are two eccentric presses driven by an electromotor. The torque is transmitted from the electromotor to the flywheel which serves to reduce impact loads. The flywheel is placed on the eccentric shaft and they rotate together. A joint which drives the eccentric press and converts the circular motion of the driving motor into the rectilinear motion of the tool is fixed to the eccentric of the shaft.

Small serial and medium serial production is most frequently realized in the workshop. The dominant operations are cutting and punching performed by using tools on the eccentric presses. Two eccentric presses whose nominal deformation forces are 800 KN and 500 KN are to be installed in the workshop.

The equivalent noise level measured at the distance of 0.7 m from the press is 95.8 dB(A).

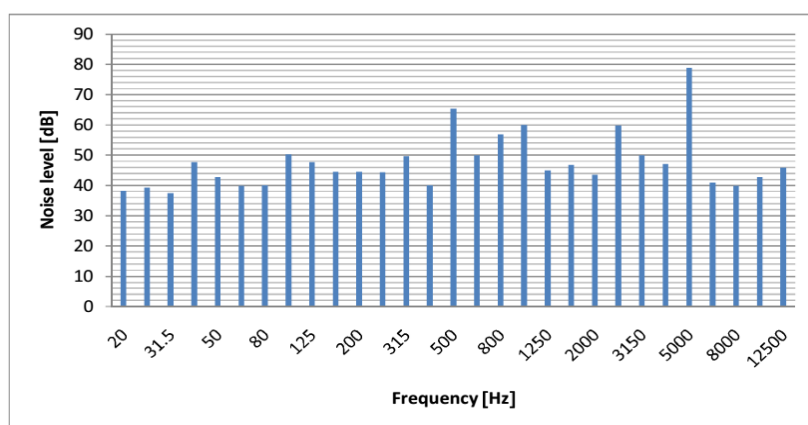

Fig. 1 Eccentric press WÖGTLE (500 KN) and its frequency characteristic at individual operation

3. METHODOLOGY OF ESTABLISHING SOUND INSULATION

The main procedure in reducing the isolation of any two rooms to a given value means establishing all paths of the passage of sound energy between them. Adequate interventions to a necessary extent can be allowed only by complete consideration of possible paths of sound passage. A lot of mistakes in solving sound protection have been the consequence of wrongly considered significance of certain paths of energy.

The minimum values of sound insulation R_w and maximum values of the level of impact sound L_w are given in the standard SRPS U.J6.201 for individual functions of partitions as a function of purpose of the building. The acoustic insulation power, R , is a value expressed in decibels and defined as the logarithm of the reciprocal value of the transmission coefficient τ (ratio of the sound energy transmitted through the partition to the total sound energy incident on it).

$$R = 10 \log \frac{1}{\tau} [dB] \quad (1)$$

The acoustic insulation power of a solid partition at low frequencies can be approximately expressed by the following relation:

$$R = 20 \log(f \cdot m_s) - 47 [dB] \quad (2)$$

where:

f - the frequency

m_s - the surface mass of the partition.

It can be seen that the acoustic insulation power increases with the increase in the frequency and the partition mass. Due to the increase in the acoustic insulation power with the increase in the partition mass, the previous expression is often called "the law of mass". The acoustic insulation power of partitions is given in dB depending on the frequency.

3.1 Acoustic insulation power of a complex partition

Complex partitions are those partitions which include different elements or materials, e.g. a wall with an inserted window. The acoustic insulation power of a complex

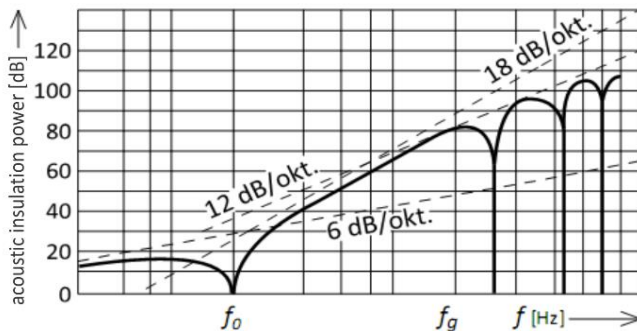

Fig. 2 Diagram of the acoustic insulation power of a double partition as a function of frequency

The double partition has the resonant frequency given by the expression:

$$f_0 = \frac{1}{2\pi} \sqrt{\frac{1,8 \cdot \rho \cdot c^2}{b} \left(\frac{1}{m_{s1}} + \frac{1}{m_{s2}} \right)} = 80,23 \sqrt{\frac{m_{s1} + m_{s2}}{b \cdot m_{s1} \cdot m_{s2}}} [Hz] \quad (5)$$

partition is determined by the acoustic insulation power of its weakest part, which means that there is no sense in making a partition of high acoustic insulation power if it will have inserted openings (doors and windows) whose acoustic insulation power is low.

The acoustic insulation power of a complex partition is determined by the expression:

$$R = 10 \log \left[\frac{1}{\left(\frac{S_z / S_u}{10^{R_z/10}} \right) + \sum_{i=1}^n \left(\frac{S_{oi} / S_u}{10^{R_{oi}/10}} \right)} \right] [dB] \quad (3)$$

$$S_z = S_u - \sum_{i=1}^n S_{oi} \quad (4)$$

where:

S_u - the total area of the partition, m^2

S_o - the area of the opening, m^2

S_z - the pure area of the wall, m^2

R_z - the acoustic insulation power of the wall, dB

R_o - the acoustic insulation power of the opening, dB

3.2 Acoustic insulation power of a multi-layer partition

Multi-layer partitions consist of a certain number of solid partitions (walls) with an air gap. This gap is relatively narrow and the whole structure made of walls with the gap must be observed as a unit. These partitions are, for practical and economical reasons, most often made as double partitions. Double partitions, due to the air gap, have the resonant frequency. In the neighbourhood of resonance, the acoustic insulation power of these partitions is reduced, whereas above the resonant frequency it increases with the speed of 18 dB/ octave.

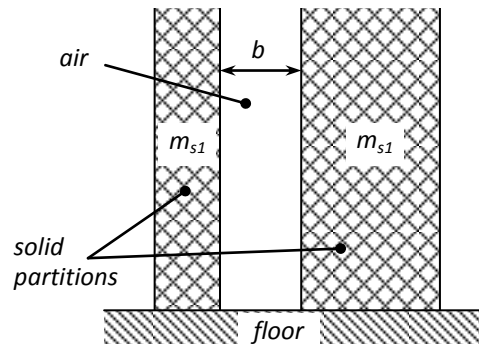

where:

m_{s1} and m_{s2} - the surface masses of the partitions, kg/m^2

$$m_s = d \cdot m_t [kg/m^2] \quad (6)$$

where: d - the thickness of the partition in cm

m_t – the surface mass of the material [$kg/m^2, cm$] (table value)

b - the distance between the partitions, m.

Below the resonant frequency, the acoustic insulation power is identical to the one of a solid homogeneous partition whose surface mass is equal to the sum of surface masses of individual partitions, i.e.

$$R \approx 20 \log [f \cdot (m_{s1} + m_{s2})] - 47 \text{ [dB]} \quad (7)$$

The acoustic insulation power below this frequency increases with the speed of 6 dB per octave.

It can be taken that the improvement of the acoustic insulation power due to the existence of a double partition structure approximately begins only at the frequency which is by an octave higher than the resonant frequency f_0 given by the expression (5).

With a further increase in frequency, the acoustic insulation power increases by 18 dB/oct. In this zone, the acoustic insulation power is proportional to the product of surface masses of individual partitions and distances between them, i.e.:

$$f_g = \frac{c}{2 \cdot \pi \cdot b} \approx \frac{55}{b} \text{ [Hz]} \quad (8)$$

At the frequency f_g , the acoustic insulation power is found from the relation:

$$R_{(f_g)} \approx R_1 + R_2 + 20 \log (f \cdot b) - 29 \text{ [dB]} \quad (9)$$

$$R_1 \approx 20 \log (f \cdot m_{s1}) - 47 \text{ [dB]} \quad (10)$$

$$R_2 \approx 20 \log (f \cdot m_{s2}) - 47 \text{ [dB]} \quad (11)$$

3.3 Isolation

The isolation between two rooms depends on the the acoustic insulation power of the partition, the area of the common wall and the total area of the reception room. The isolation can be determined by the expression:

$$D = R - 10 \log \frac{S_{12}}{A_2} \text{ [dB]} \quad (12)$$

where:

D – the isolation

R – the acoustic insulation power of the partition

S_{12} – the area of the common wall

A_2 – the total absorption area of the other room

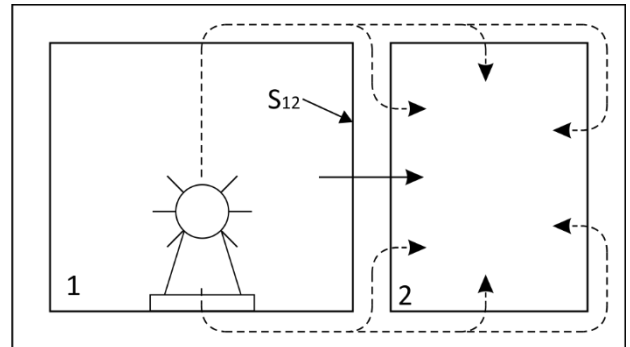

Fig. 3 Paths of transmission of sound energy between two rooms

The noise level in the reception room is calculated according to the expression:

$$L_2 = L_1 - D \text{ [dB]} \quad (13)$$

where:

L_1 – the noise level in the room where the source is placed

L_2 – the noise level in the reception room

4. CALCULATION OF THE SOUND INSULATION OF THE MECHANICAL WORKSHOP

Workshop – 1 is located in the business facility shown in Figure 4.

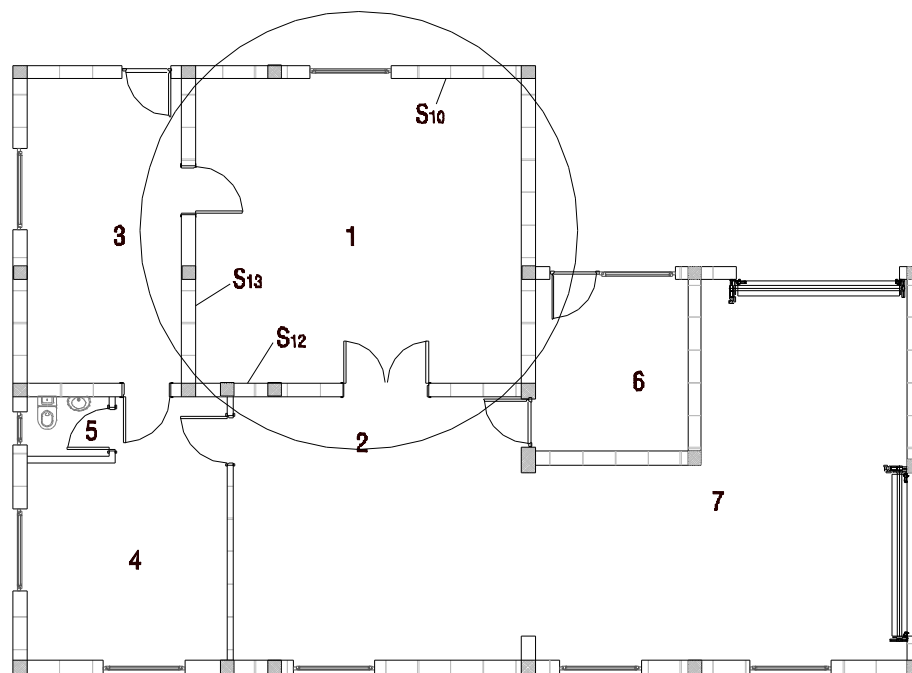

Fig. 4 Base of the ground floor where the mechanical workshop is located

The necessary isolation of walls of the mechanical workshop is determined for each wall depending on the purpose of the neighbouring rooms.

In the mechanical workshop, the critical wall is S_{10} because it represents a complex partition with an inserted window. That wall borders its residential surroundings and represents a potential danger from the aspect of noise. The problem is enhanced by the fact that the facade of the closest residential unit is only 5 m away from the workshop window.

Table 1 Rooms of the business facility

Ord. no.	Name of the room	Floor treatment	Floor area [m ²]
1.	Mechanical workshop	reinforced concrete	33,57
2.	Workshop - 2	reinforced concrete	25,73
3.	Storeroom for wood	reinforced concrete	15,94
4.	Storeroom for coal	reinforced concrete	15,87
5.	Sanitary block	ceramic tiles	1,65
6.	Office	ceramic tiles	8,79
7.	Garage	reinforced concrete	38,35

4.1 Selection of materials for the walls

YTONG blocks were selected from the wall building materials that can be found in the market. The selection was done on the basis of price and acoustic insulation power. One wall of the workshop does not have any acoustic openings. The other three walls have a window, a single-wing door and double-wing door, as it is shown in Figure 3. The appearance of the selected block for walls is seen in Figure 5., and the main technical characteristics are presented in Table 2.

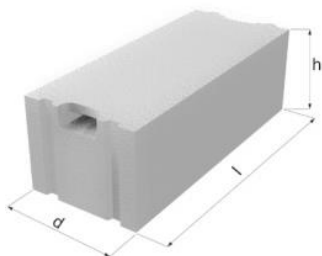

Fig. 5 Appearance of YTONG block ZBZ 25** [8]

Table 2 Catalogue data for YTONG block ZBZ 25** [8]

Type of materials	Label	Dimensions			Sound insulation [dB]
		l	d	h	
P-5,0/0,65	ZBZ 25**	625	250	200	52

The acoustic insulation power of the block is presented in Figure 6. It is a figure from the manufacturer's catalogue and it also presents the values of acoustic insulation power for other types of building blocks.

The blocks are manufactured in two variants of density. Blocks with higher density (marked by** in the manufacturer's catalogue) are used for the walls which require higher acoustic insulation power. The block with the acoustic insulation power of 52 dB was selected (Figure 6.) for the walls of the mechanical workshop.

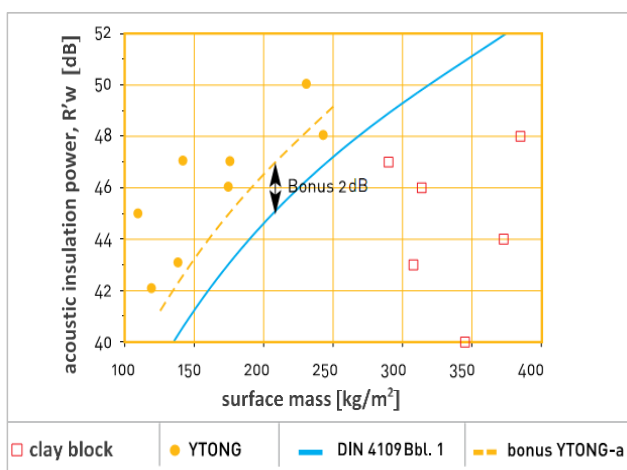

Fig. 6 Values of the sound insulation RW for YTONG block ZBZ 25** [8]

4.2 Acoustic insulation power of windows and doors

The calculation of acoustic insulation power of windows can be determined according to the expression:

$$R = 20 \log d + 12 \log (2.5 + b) + 25 [dB] \quad (14)$$

where:

d – the total thickness of the pane, cm

b – the distance between the panes

The window on the wall has three panes. The thickness of the pane is 4 mm, and the distance between the panes is 9 mm. The acoustic insulation power R of such a window is 36 dB.

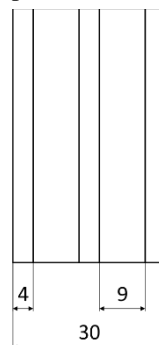

Fig. 7 Three-chamber window (measures given in mm)

Table 3 Classification of windows and doors into classes of acoustic quality (according to the standard SRPS U.J6.201)

WINDOWS		DOORS	
class	acoustic insulation power [dB]	class	acoustic insulation power [dB]
special class	> 40	special class	> 35
Class I	35 - 39	Class I	30 - 34
Class II	30 - 34	Class II	25 - 29
Class III	25 - 29	Class III	20 - 24
Class IV	20 - 24	/	/

According to Table 3, it can be concluded that the window belongs to Class I of acoustic quality.

4.3 Calculation of acoustic insulation power of the walls which represent complex partitions

In the mechanical workshop, three walls are realized as complex acoustic partitions. These walls have openings which are, in principle, always weak acoustic points.

Table 4 Acoustic insulation power of the workshop walls which represent complex partitions

Ord. no.	Opening	Designation of the wall	S_u	S_z	S_o	R_z	R_o	R
			[m ²]	[m ²]	[m ²]	[dB]	[dB]	[dB]
1.	Window	S ₁₀	18	16.77	1.28	52	36	46 (46.2)
2.	Single-wing door	S ₁₃	16.8	14.91	1.89	52	30	39 (39.3)
3.	Double-wing door	S ₁₂	18	9.52	8.48	52	30	33 (33.2)

Figure 8. presents the wall with an inserted window. The sizes of the wall and the window are given as well as the position of the window on the wall.

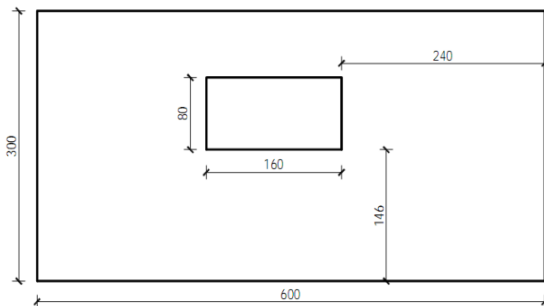

Fig. 8 Wall with an inserted window

4.4 Calculation of the acoustic insulation power of the ceiling

The ceiling is realized as a double partition which consists of brick with the thickness of 200 mm and the concrete screed with the thickness of 30 mm. The plates are completely mechanically and acoustically isolated from each other and the gap between them is filled with styropor with the thickness of 50 mm (Figure 9.). The surface mass of the blocks m_{s1} is 21 kg/m², and the surface mass of concrete is 23 kg/m².

Based on Figure 2 and the expressions (5) through (11), the necessary values which influence the acoustic insulation power of the multi-layer partition, in this case the ceiling, can be determined. The results of calculation are presented in Table 5.

Table 5 Acoustic insulation power of the ceiling

m_{s1}	m_{s2}	f_o	R	f_g	R_1	R_2	R_{fg}
[kg/m ²]	[kg/m ²]	[Hz]	[dB]	[Hz]	[dB]	[dB]	[dB]
420	69	46,6	37	1100	66,3	50,6	123

The acoustic insulation power R is calculated for the frequency of 31.5 Hz.

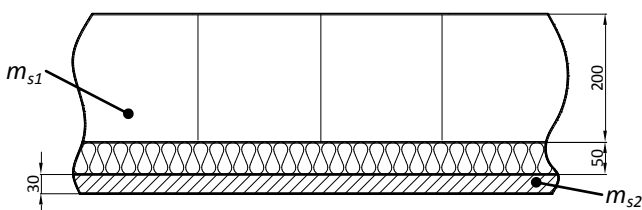

Fig. 8 Ceiling in the mechanical workshop

Openings reduce the value of acoustic insulation power, but they cannot be avoided because of the purpose of the room.

Table 4. presents the results of calculation of acoustic insulation power of complex partitions of the mechanical workshop. The values are determined according to the expressions (3) and (4).

4.5. Isolation of the mechanical workshop

The isolation (D) from the neighbouring rooms of the mechanical workshop was calculated based on the calculated acoustic insulation power of the partitions (R_w), the area of the common walls (S_{1i}) and the total absorption area of the reception rooms.

Table 6 Isolation of the mechanical workshop

Connection between the rooms		R_w	S_{1i}	A_2	D
		[dB]	[m ²]	[m ²]	[dB]
workshop - 1	workshop - 2	33	15,9	112,5	41,2
workshop - 1	room - 3	39	16,8	82,6	45,9
workshop - 1	external environment	46	18	18	46

In the middle of the mechanical workshop in which two eccentric presses operate simultaneously, the noise level is 94 dB(A).

In the case of the mechanical workshop, it is most important to determine the noise level toward the external environment. The noise level in the reception room can be calculated based on the calculated isolation (Table 7.) and the measured noise level in the workshop. Since in this case there is no room, but an external environment, the noise level was measured directly on the window.

Table 7 Isolation of the outer wall of the workshop

Measuring point	Workshop	Window (theoretically)	Window (experimentally)
Noise level	[dBA]	[dB]	[dBA]
	94	48	47

As the workshop is located in the business-residential area (acoustic zone IV with the allowed values of noise indicators for daily conditions of 60 dBA, and 50 dBA for night conditions), its isolation is sufficient to provide the noise level in the environment within the allowed limits.

For experimental determination of the acoustic insulation power of each partition, it is necessary to perform measurement according to the standards SRPS ISO 717-1 and SRPS ISO 717-2.

5. CONCLUSION

The calculated values of acoustic insulation power of the walls of the mechanical workshop determined by theoretical models and the experimental results obtained by measurement of noise levels, after the completion of the mechanical workshop, coincide to a great extent. Based on this, it can be concluded that the theoretical model is adequate. The designed sound isolation of the workshop for storing eccentric presses provides such values of noise levels in the workshop environment that will not result in exceeding the limit values of noise indicators in the environment. Such a solution of sound protection can be applied in other similar cases of workshops which store machines that generate high noise levels.

Acknowledgement: The paper is a part of the research done within the project TR37020. The authors would like to thank to the Ministry of Education and Science of the Republic of Serbia for supporting this research.

REFERENCES

- [1] Radičević B., Petrović Z., Todosijević S., Petrović Zv., „Design of noise protection of industrial plants – case study of a plywood factory“, 23rd National Conference & 4th International Conference “Noise and vibration”, Niš, 2012, pages 71-75
- [2] Petrović, Z., Radičević, B., Šoškić Z., Bjelić, M. - Zaštita od buke industrijski postrojenja - Buka i vibracije, XXI konferencija sa međunarodnim učešćem, Tara 2008
- [3] Petrović Z., Radičević B., Bjelić M., „Designing main fan noise protection system in mine “Jarando“ – Baljevac“, Podzemni radovi, br.15, (133-138), Rudarsko geološki fakultet, Beograd, 2006
- [4] Drinčić D., Pravica P., ”Akustika – zbirka rešenih zadataka”, Visoka škola elektrotehnike i računarstva strukovnih studija, Beograd, 2011
- [5] Standard: SRPS ISO 1996-1: 2010, Opisivanje, merenje i ocenjivanje buke u životnoj sredini - Deo 1: Osnovne veličine i procedure ocenjivanja
- [6] Standard: SRPS ISO 1996-2: 2010, Opisivanje, merenje i ocenjivanje buke u životnoj sredini - Deo 2: Određivanje nivoa buke u životnoj sredini
- [7] Standard: SRPS U.J6.201: 1990, Akustika u građevinarstvu – Tehnički uslovi za projektovanje i građenje zgrada
- [8] <http://www.ytong.rs>
- [9] <http://www.index-spa.com>