

# Variable Tribological Conditions on the Blank Holder as Significant Factor in Deep Drawing Process

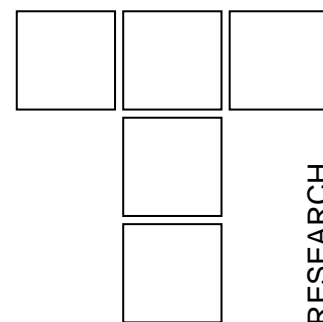

*Friction on the work part flange very significantly influences the deep drawing process. Blank holding force (BHF) is normal force for that friction.*

*Presented in the paper are short review of analysis of for type variable BHF (VBHF) influence during the process. The experimental researches were performed on a special laboratory computer device. Realized are pure deep drawing process (drawing ratio 2) of the Al-alloy sheet metal, with dry surfaces. Influence of VBHF monitored mainly through thinning strain distributions and drawing depth.*

*After performed experiments we can conclude that some type of VBHF are important factor for advancing deep drawing process.*

**Key words:** deep drawing, variable blank holding force, aluminum alloy sheet

## 1. INTRODUCTION

Thin sheets are most important materials in the modern industry, and deep drawing is one of dominant technology.

On the deep drawing forming process tribological factors have the same influence as other forming system factors (material, tools and machine) [1]. Possibility of process control by changing of friction intensity in zone 5 (fig. 1) on the flange is very interesting. We can make that by changing contact conditions (different regimes of lubrication) and by changing blank holding force which represents the normal friction force in the sheet-blank holder contact.

Flange friction significance was shown in many researches. Forming force may decrease to 50% by complete elimination of flange friction. If we eliminate friction in the zone 4 (fig. 1) forming force may decrease up to 20 % [2].

The main purpose in this investigation is try to find optimal functions of BHF and contact pressure (which is effect of BHF) change during the process. That kind of BHF leads to advancing of process performance and forming part properties.

Srbislav ALEKSANDROVIĆ, Ph. D., Ass. Prof.,  
Milentije STEFANOVIĆ, Ph.D., Prof.,  
Faculty of Mechanical Engineering, Kragujevac,  
Serbia and Montenegro  
Tomo VUJINOVIĆ, MSc,  
Rudi Cajavec, Banja Luka, Republic of Srpska,

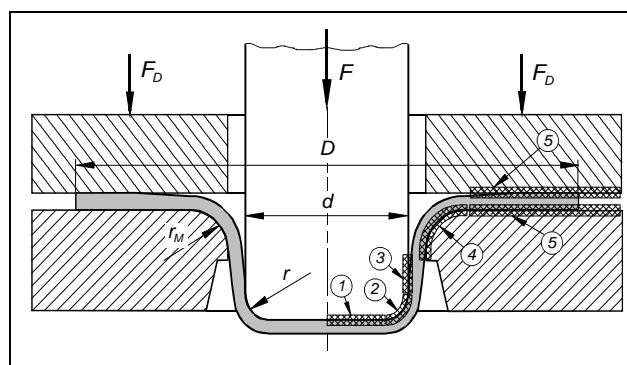

Figure 1. Friction zones in deep drawing process

In a modern computer systems for measurement and control it is possible to realize any given VBHF and contact pressure function in dependence on punch travel and time. In that way friction conditions are changing, and also forming process results.

Process stability is double endangering. On one side there is danger of flange wrinkles appearance (it is necessary to enlarge BHF), and on the other side is sheet metal thinning in critical zone that lead to fracture (BHF must reduce).

Task is difficult, even theoretically it is not so easy to define BHF optimal dependence during the process. Available methods are: application of computer simulations by using different software packages and experiments.

This paper gives experimentally analysis of for suggested variable blank holder force (VBHF) types influence on the results of pure deep drawing process of aluminum alloy AlMg4, 5Mn work piece.

The experimental researches, some results of which are given in this paper, are carried out at the Faculty of Mechanical Engineering (Kra-gujevac, Serbia and Montenegro) where special, measurement and control laboratory device for researching VBHF influence on the deep drawing process has been made (more details in [3] and [4]).

## 2. METHODOLOGY OF INVESTIGATION

Cylindrical work piece geometry (pure deep drawing,  $D_0=100$  mm,  $d=50$  mm,  $r_M=3,5$  mm; Fig. 1) was chosen. Drawing ratio is 2 (little bit smaller then limiting drawing ratio). Contact conditions was dictated by application of dry contact surfaces degreased by acetone (marked as dry or D). In this condition coefficient of friction has high value and BHV much better influence. If coefficient of friction get down possibilities of BHF influence are worse. In quasi hydrodynamic regime of friction that influence are negligible.

First part of experiment was carried out with application of constant BHF, which intensity was determined as medium value of empiric recommendations and results of author's particular researches. That value is  $F_D=6160.4$  N. Appropriate constant value of contact pressure is  $q=1.195$  MPa.

For determining of VBHF and contact pressure functional dependencies it is necessary to define flange area. All of this three variables can be monitored in dependence on time or drawing depth (punch travel).

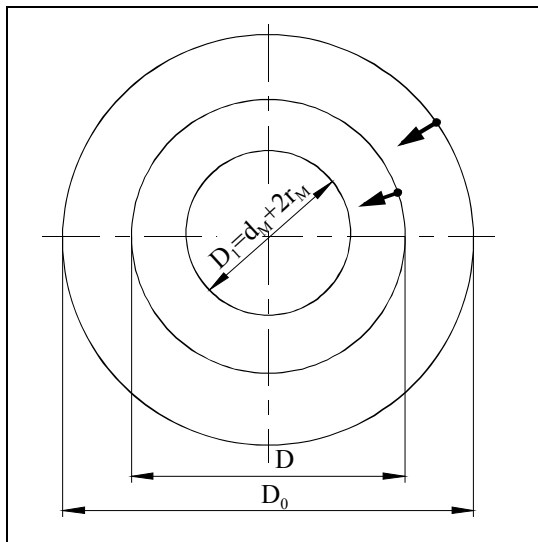

Figure .2 Flange area change durig the process

Flange area is (fig. 2):

$$A_D = \frac{\pi}{4} [D^2 - (d_M + 2r_M)^2], \text{ mm}^2.$$

With hypothesis about linear dependence of the outer flange diameter  $D$  and time  $t$  (error is negligible at constant forming speed) following expression is easily obtained:

$$A_D = A_{DP} - \frac{\pi}{2} D_0 \frac{D_0 - D_1}{T_1} t + \frac{\pi}{4} \left( \frac{D_0 - D_1}{T_1} \right)^2 t^2, \text{ mm}^2.$$

Starting flange area is:

$$A_{DP} = \frac{D_0^2 - (d_M + 2r_M)^2}{4} \pi, \text{ mm}^2.$$

Die diameter  $d_M \approx d + 2s$ , mm ;  $s$  is sheet thickness.

In concrete case, for time  $T_1= 104$  sec starting diameter  $D_0=100$  mm decrease to  $D_1=58,6$  mm (fig. 2). Sliding over die radius lasting about 15 sec. Whole work piece depth (medium value 39 mm) achieve for about 119 sec.

Like in case of flange diameter it is convenient to established linear relationship between punch travel (drawing depth) and time. Obtained dependence is:

$$t=3.05h, \text{ sec.}$$

$$t=3.05h, \text{ sec.}$$

Considering above expressions and data, flange area is:

$$A_D = 5157 - 62.5t + 0.124t^2$$

$$A_D = 5157 - 190.6h + 1.153h^2 .$$

First type of VBHF is so called decreasing dependence (marked DEC). Principle, on which decreasing VBHF defining is based, is keeping the contact pressure constant during the process. For this aim achieving BHF have to decrease in accordance to flange area reducing. At  $q=1,195$  MPa:

$$F_D=6162-74.5t + 0.148t^2, \text{ N (fig. 3).}$$

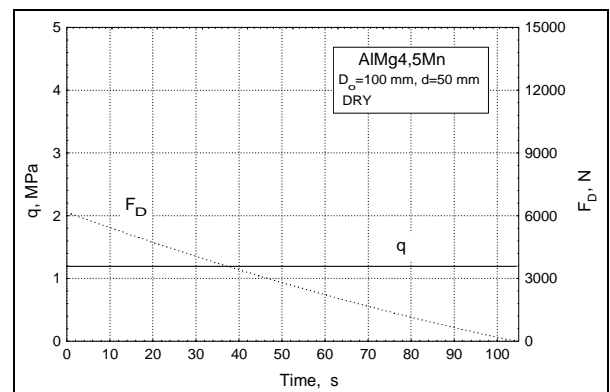

Figure 3. Decreasing BHF

Second type of VBHF is so called increasing dependence (INC). It was defined on the base of previous experiments [4] with basic idea to

successful avoid wrinkles on the flange. Obtained is following term:

$$F_D = 7238 \sin(0.0132t), \text{ N}$$

Fig. 4 shows VBHF and contact pressure dependence on time.

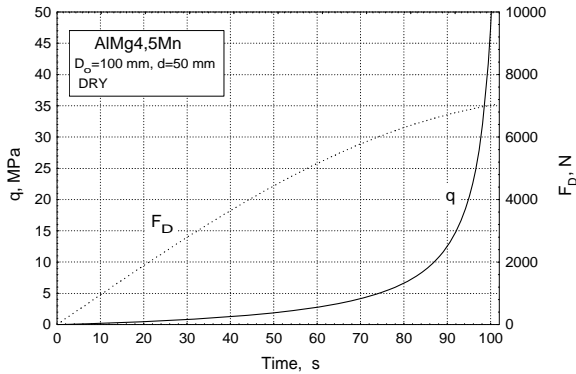

Figure 4. Increasing BHF

In this case, specific contact pressure has following form:

$$q = \frac{F_D}{A_D} ; q = \frac{7238 \sin(0.0132t)}{5157 - 62.5t + 0.124t^2}$$

Most complex form has so called combined (COMB) dependence of VBHF. Basic idea is to achieve, in a certain sense, unloading on holder, considering the drawing force, during the process. Because of limiting space it is not possible to give details about determination of functional relationship of this type of VBHF.

In concrete case, finely is obtained:

$$F_D = 38000 - (95380L + 5834), \text{ N}$$

$$L = \ln \frac{\sqrt{1.25 - \rho^2}}{0.5\rho} \ln \frac{\rho}{0.5} ; \rho = 0.916 - \frac{t}{238}$$

Fig. 5 shows: combined VBHF curve, straight line according to constant BHF and corresponding curves of contact pressure q. Left and right from marked points of cross section of constant BHF and combined VBHF it is common to make correction (instead of VBHF values are using values of constant BHF). Reason of that is unnecessary high value of contact pressure. It is possible experimentally to prove.

Fourth type curve of VBHF has pulse sinusoidal form. Without details [4] it is obtained following functions:

$$F_D = 3830 + 2330 \sin(0.264t), \text{ N}$$

Fig. 6 shows form of above curve, and also form of contact pressure q.

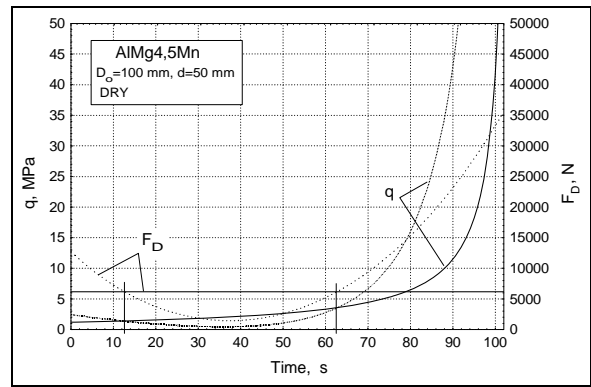

Figure 5. Combined VBHF

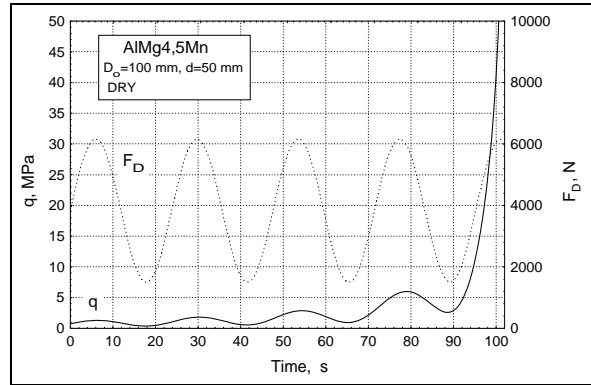

Figure 6. Pulsating VBHF

Fig. 7 shows curve of specific contact pressure q and, also straight line of constant BHF. It is possible to occur high increasing at the end of drawing process, when is flange area getting very small.

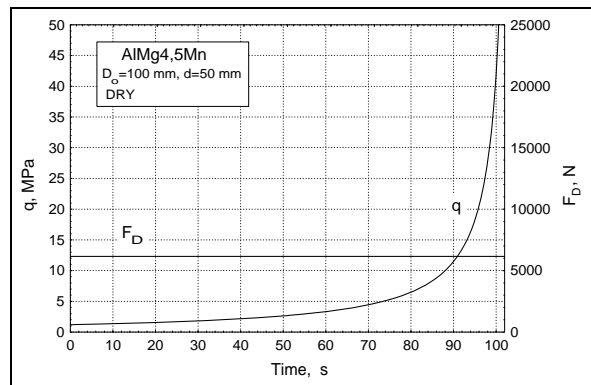

Figure 7. Constant BHF

Effects of application of VBHF is possible to monitoring through following properties: main strains in plane of sheet distributions in Forming Limit Diagram, thinning strain distributions, drawing force dependence on time (or punch travel), drawing depth change etc.

In this paper, because of limiting space, were shown distributions of thinning strain and drawing depth data.

### 3. THE RESULTS OF EXPERIMENT

The experiment are performed on previously mentioned laboratory device, which main characteristic is possibility to realize any given VBHF function in dependence on punch travel, that is time [3], [4] Maximal drawing force range is 0–130 kN and holding force 0–34 kN. Used forming speed is 20 mm/min.

Work piece material is sheet made of aluminum alloy marked as AlMg4,5Mn (manufacturing Sevojno, Serbia and Montenegro). It is AlMg 5000 series alloy which basic characteristic is forming whitout any termic treatment. Plastic forming formability is relatively bad. Partially, it is visible in tab. 1.

Table 1. Basic mechanical and formability properties

AlMg4,5Mn $s_0=0.8$ mm					
$R_M$	$R_P$	$R_P/R_M$	$A_{80}$	$n$	$r$
MPa	MPa		%	–	–
271.1	148.2	0.545	20.9	0.26	0.715

Roughness properties are:  $R_a=0,31\mu\text{m}$ ,  $R_p=0,66\mu\text{m}$ ,  $R_z=1,49\mu\text{m}$ ,  $R_t=1,72\mu\text{m}$  i  $P_C=56$  l/cm.

More details about properties of this material are given in [4].

From table 2 is visible that maximal achieved drawing depth with constant BHF is 12.43 mm. With decreased and pulsating VBHF there is no important changes. Regime of increased VBHF makes little advancing (7,6%), but significant advancing is occur by application of combined VBHF (20.1%).

Table 2. Deep drawing depths

	Variable BHF				
	Const. BHF	DEC	INC	COMB	PULS
Depth mm	12.43	12.22	13.38	14.93	12.8
Percent		-1.7	7.6	20.1	3

Fig. 8 shows comparatively distribution curves of thickness nature deformation in the case of constant BHF and for types of VBHF. By carefully observing it is possible to occur that curve corresponding to combined VBHF regime have smaller local thinning on the location 8 relatively to other curves. In this way thinning distribution is better, and that is in

completely accordance with achieved maximal drawing depth.

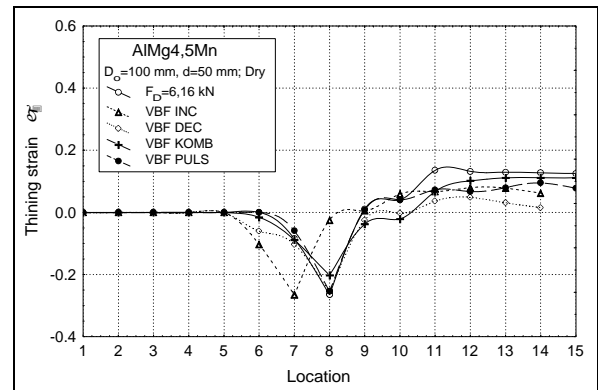

Figure 8. Distributions of thinning strain

At the end fig. 9 shows experimentally obtained both drawing and BHF curves at combined regime of VBHF.

### 4. CONCLUSIONS

The application of VBHF can be a significant means for the improvement of technological results (especially for low formability materials) and better understanding of the essence of the deep drawing process.

Sheet metals made of Al–alloys are falling into category of less formable materials. Because of that, application of VBHF is the way to solve or reduction forming problems, especially in auto-motive industry.

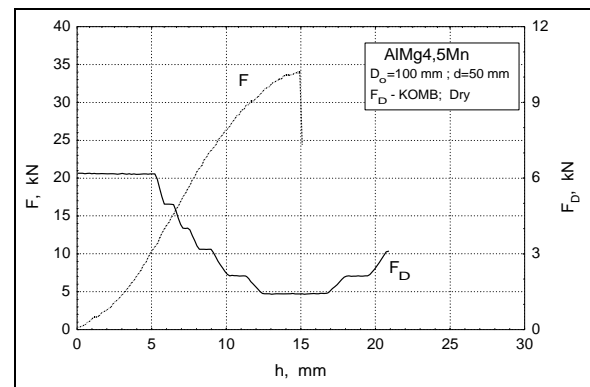

Figure 10. Drawing and BHF forces

Results given in this paper (in very reduced form) point to positive influence of so called combined VBHF, especially in conditions of more prominent friction (dry friction), which is clearly visible in the more convenient thickness strain distribution, and increase of draw depth over 20%.

Further researches will include work part geometry with drawing ratio closer to limiting combined with smaller coefficient of friction. Such conditions are more likely to real process conditions in industry.

The final aim is to give the following answer in any case of forming by deep drawing: which form of blank holding force shape for particular process conditions represents optimal solutions.

### **REFERENCES**

- [1.] Stefanovich M.: Tribology of deep drawing, Yugoslav Society for Tribology and Faculty of Mechanical Engineering, Kragujevac, 1994, (In Serbian).
- [2.] Emmens W.: Tribology of Flat Contacts and its Applications in Deep Drawing, PhD thesis, University Twente, Netherlands, 1997.
- [3.] Aleksandrovich S., Stefanovich M., Vujinovich T.: Increasing Blank Holding Force as Tribologic Factor at Pure Deep Drawing of Coated Sheets in Conditions of Nonmonotonous Forming, YUTrib, 2001, Belgrade, Proc., pp. 3-9 to 3-12.
- [4.] Aleksandrovich S.: Deep Drawing of Thin Sheets in Nonmonotonous Forming with Variable Tribological Conditions, PhD thesis, Faculty of Mechanical Engineering, Kragujevac, 2000, (In Serbian).