

PAPER • OPEN ACCESS

CAD modeling of the closing HIGH TIBIAL OSTEOTOMY

To cite this article: N F Cofaru *et al* 2019 *IOP Conf. Ser.: Mater. Sci. Eng.* **659** 012033

View the [article online](#) for updates and enhancements.

CAD modeling of the closing HIGH TIBIAL OSTEOTOMY

N F Cofaru¹, I I Cofaru¹, V Marjanović², N Marjanović², M Blagojević² and R E Petrușe¹

¹University “Lucian Blaga” of Sibiu, Faculty of Engineering, Emil Cioran 3, 550025 Sibiu, Romania

²University of Kragujevac, Faculty of Engineering, Sestre Janjić 6, 34000 Kragujevac, Serbia

E-mail: nicolae.cofaru@ulbsibiu.ro

Abstract. The article proposes a generalised CAD modeling for a surgical strategy applied to the axial deviations of the human leg. These deviations appear most of the cases from a most common disease nowadays, gonorrosys characterised by usage of the knee’s articular cartilage. The surgical strategy is HIGH TIBIAL OSTEOTOMY and it is very appropriate in order to correct the axial deviation due several reasons such as: repair with good results the axial deviations, good rate price/quality, strongly recommended method for young patients, not needed a maintenance activity as in case of the prosthesis. In the article it starts with the presentation of the mechanical axis of the lower limb and of the axial deviations that might appear and then using the CAD type modeling tools it is simulated and modelled the surgical procedure: Closing High tibial osteotomy. The approach is very important both from didactically consideration and possible evaluations presurgical, intrasurgical and postsurgical.

1. Introduction

The 3D modeling of the bones of the human lower limb, assembly of these structures in different ways for healthy subjects but especially for the subjects affected by different diseases in this part of the body, is an important problem that must be taken in consideration in order to establish the best way for treatment and for the correctitude of the simulation of the surgery procedures. CAD modeling of the anatomical structures is a very useful method in the biomedical field since the objects of the study, human body parts, cannot be removed and studied as experimental objects.

The utility of the method results in a clear manner from the previous approaches which are founded in the anterior researches [8, 9, 7]. In those articles CAD-CAE methods proved its efficiency.

The advantages of CAD modeling are: a better assessment of the concrete situation on the custom model, compatibility analysis with implants and transplants found in 3D databases, and the educational role in supporting the learning these techniques using virtual models.

The CAD modeling which we will achieve in this article is applied for simulation of the surgical procedures: Closing High Tibial Osteotomy. For the beginning in order to have a clear image of the subject, a presentation of the mechanical axis of the leg is made.

A correct alignment of the bones of the human lower member is defined by collinearity of the line segments which unite the centre of the hip joint, the centre of the knee articulation and the centre of the ankle (figure 1). Any swerve from this axis becomes an axial deviation and it has important consequences on the health and on the comfort of the patient affected by these deviations.

The main cause of this deviation is unicompartamental gonorrosys malady that unfortunately is more and more common today. The effect of this malady is the wear of the articular cartilage which



leads to an incorrect loading of the knee and thus to the appearance of the deviations. These deviations cause an abnormal strain of the knee & displacement of the mechanical axis from the centre to the medial or lateral (figure 2).

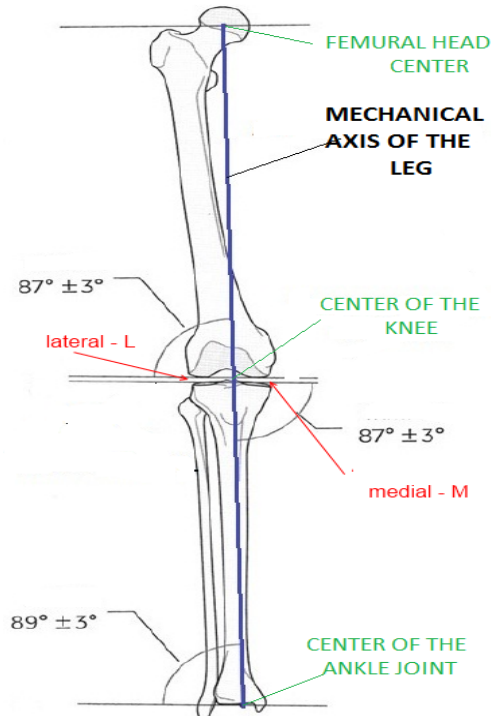

Figure 1. Mechanical axis of the leg.

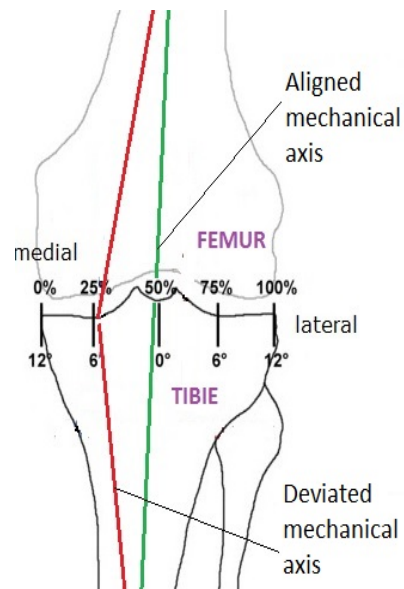

Figure 2. Aligned and Deviated mechanical axis.

The worn-out cartilage will be overstrained, which further causes its wear and therefore further increase the deviation. The two effects potentiate each other, a vicious circle which will lead to generalized arthrosis changes in the knee joint.

One of the most common surgical procedure used to correct these axial deviations is surgical technique called High Tibial Osteotomy.

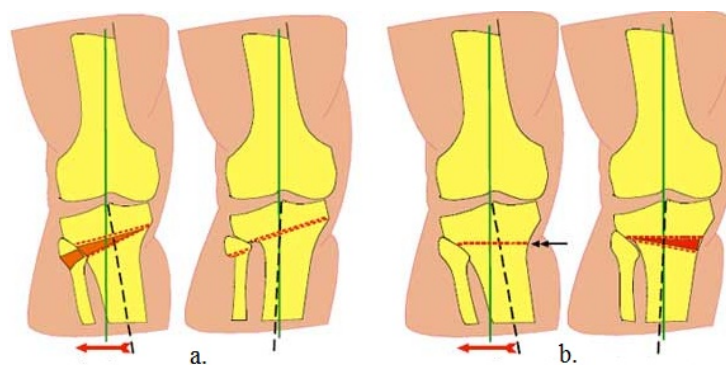

Figure 3. High tibial osteotomy (a – closing, b – opening).

Tibial osteotomy is a surgical technique that involves creating a bone wedge at the proximal tibia level to realign the bones of the lower limb. The osteotomy technique is fully recommended for younger patients because in their case it the recovery is relatively quick. In addition, this technique does not exclude the possibility of partial or total prosthetic intervention, if needed later on.

The purpose of the proximal tibial osteotomy is the realignment of the mechanical axis of the lower limb and the redistribution of the forces in the joint to unload the impacted area.

High tibial osteotomy can be one of a closing or of an opening (figure 3) [6].

For the closing osteotomy (figure 3.a.) the cuts are made, the bony wedge that results being removed, and the bony fragments are being realigned by closing the wedge. In the case of an opening only one cut is made, the fragments are realigned, resulting in an empty space by opening the wedge (figure 3.b.).

The both surgical techniques have advantages and disadvantages [2]. For opening high tibial osteotomy the advantages are: accurate corrections, no fibular osteotomy, correction in 2 plans, no limb shortening and disadvantages are: bone graft/spacer material, risk of delayed and non-union, risk to increase tibial slopes, patella height and patella-femoral pressure. In the case of lateral closing wedge osteotomy the most important advantages are the greater potential of correction, no need for bone grafting and faster healing. The disadvantages are risk to peroneal injury, muscle detachment, shortening of the leg and loss bone stock.

Taking in account the fact that closing wedge osteotomy has the important advantage of a more accurate correction with less morbidity in this paper we achieved the 3D CAD parameterized modeling of this surgical techniques.

2. Geometrical elements that are necessary for the planning of the intervention

As presented in the last chapter the mechanical axis of the lower member merging the centre of the femur's top with the centre of the ankle. We observe (figure 4) that in case of the knee affected by axial deviation this axis does not cross the middle of the knee and it is closer to the medial zone of the knee or is possible even to be less than 0% and it passes outside the joint, aspect which needs to be corrected.

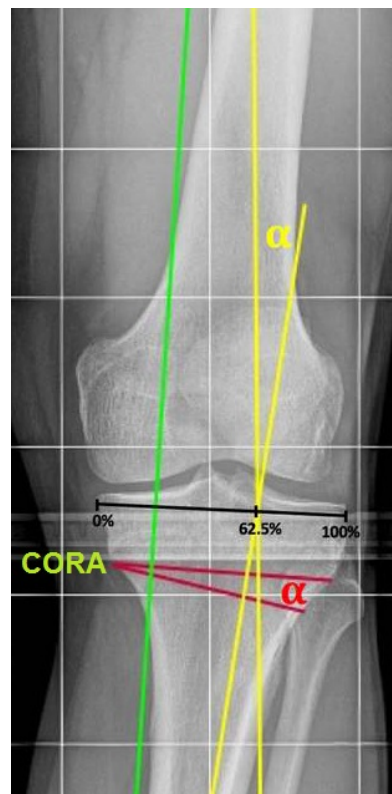

Figure 4. Determination of the correction angle α [1].

Generally patients with gonorhrosis have a predisposition to a new axial deviations. From this reason the goal of the closing high tibial osteotomy is to lead the mechanical axis of the leg (the green line in figure 4) not in the neutral position (50%) but in the point corresponding to the 62.5% of the tibial plateau width. It is achieved an over-correction. In young patients with a minimal degeneration of the medial compartment, correction to a neutral mechanical axis is planned [1].

The angle of the correction α is formed by the yellow lines from figure 4. The yellow lines run from the point situated at the 62.5% of the tibial plateau width to the centre of the hip and centre from the ankle.

The establishment of the hinge point CORA (figure 4) is made close to the border of the tibia so that the angular rotation is realized, but while assuring that don't affect the medial cortex of the tibia. The first cutting plane is placed parallel to the tibial plateau, 2–2.5 cm below the articular joint line, taking in account the inclination of the tibial plateau. From the bone's lateral it is recommended to leave a distance of 5-10 (mm). The second cutting plane is a normal plane on frontal plane of the knee and make the correction angle with the first cutting plane. Obviously CORA is a line situated at the intersection of the cutting planes.

The presentation of the geometrical elements mentioned above highlights a part of the geometrical parameters which are important for achieving the intervention. These are: the correction angle α , the placement of the hinge point or CORA. Other parameter which can be studied is the diameter of the relieving stress hole realized in CORA.

So that these parameters are easy to control (even by the laymen in aided modeling) we propose a parameterized modeling, with wide possibilities of customization, of the tibia closing osteotomy.

3. The parameterized modeling of the tibia closing osteotomy

In order to achieve a parameterized modeling [4], [5] which, only by modifying the parameters on the model, creates all the possible situations, the creation of a system of points and planes, according to which the parameterization will be realized, has to be done.

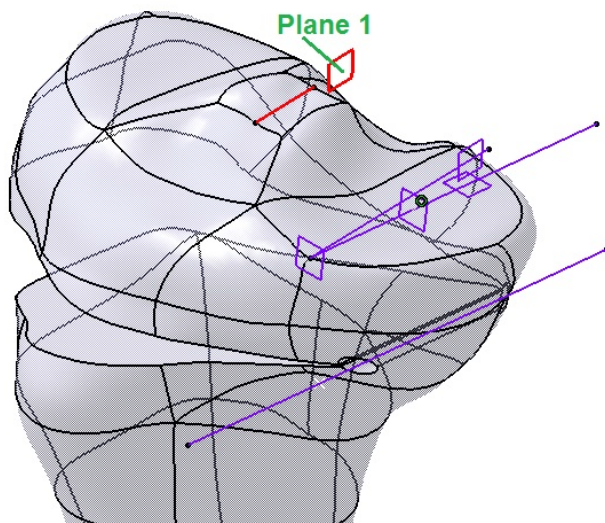

Figure 5. Creation of the sagittal plane of the tibia.

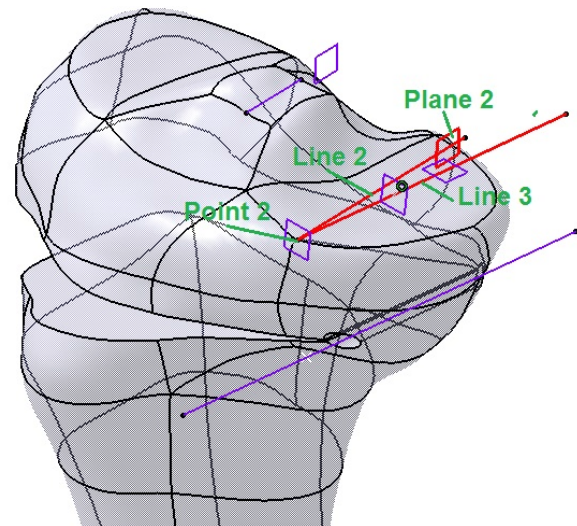

Figure 6. Modeling of the tibial plateau inclination.

First step is the creation of the sagittal plane of the tibia. To materialize this plane, a parallel line with the sagittal plane of the human body is created. This line crosses the middle of the tibia line and through this a plane is being constructed (Plane 1). The plane forms a 90° angle with the horizontal plane (figure 5).

In order to highlight the posterior tilt with a 7° angle of the tibial plateau, Point 2 has to be defined on the tibial plane, in the centre and boundary to the intersection with the anterior surface of the tibia. Through this point Line 2 will be defined as parallel to the one defined at the previous step. Through this line, a Plane 2 rotated with 0° (parallel) towards Plane 1, and in his plane Line 3 at 7° towards Line 2 (figure 6.). For the modeling 3 planes, perpendicular on the inclination line of the tibia plane, are constructed: Plane 4 through a point situated at the middle of the tibia and normal to Line 3, Plane 5 through Point 2 and also normal of the line 3 and Plane 3 through Line 3 and normal of the Plane 4 and 5 (figure 8).

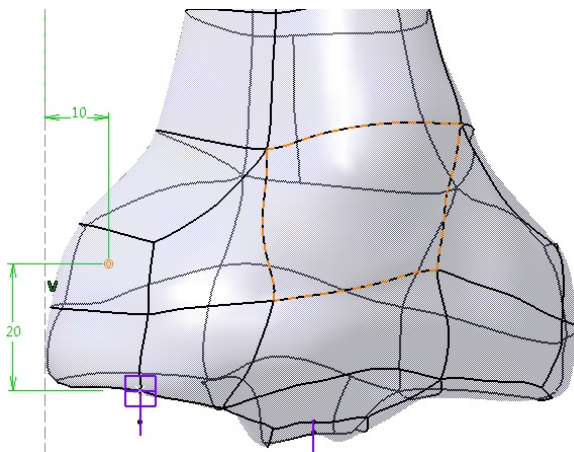

Figure 7. Determination of the CORA positions.

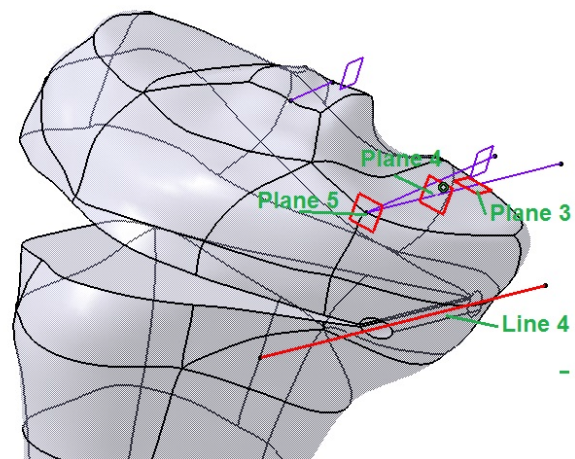

Figure 8. Determination of the hole axis in CORA.

The next step is the execution of the relieving stress hole in the hinge (CORA). This step consists in the making of a hole which has a double role: eliminating the stress concentrators from the bottom of the osteotomy wedge and limiting the lateral cutting plan. For this it was made a first sketcher (figure 7.) in the Plane 5 in order to determine the position of the CORA. This point is situated at 10 mm measured from the tangential plan of the medial cortical surface of the tibia and 20 mm measured from the Plane 3. These coordinates could be parameters that will be taken into account in further approaches. Through this point Line 4 will be defined normal to the Plane 5. Line 4 will be axis for the relieving stress hole. It is worth mentioning that the hole is not horizontal but parallel to the tibia planes. This method of modeling, apparently more complicated, was also created with the purpose of offering the model a high degree of generality [1].

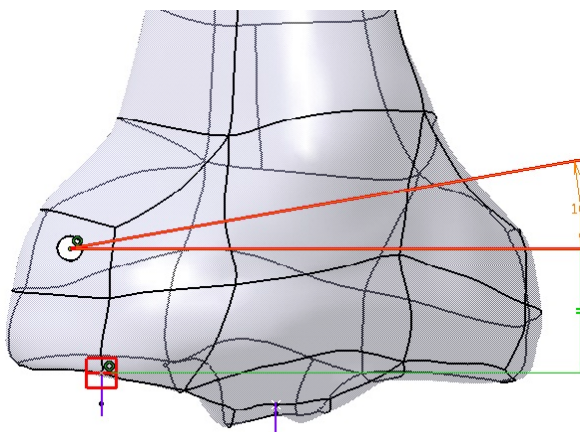

Figure 9. Sketcher for the closing wedge.

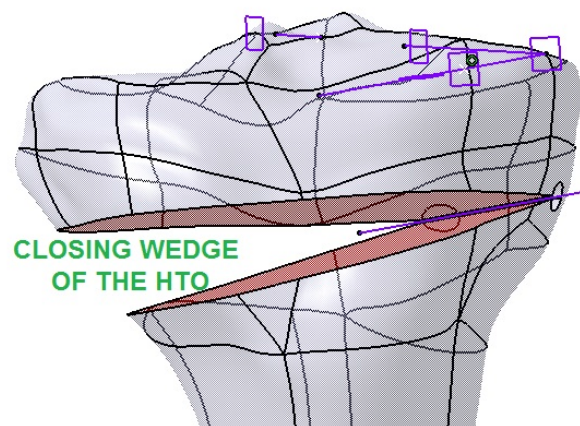

Figure 10. Achieving the closing wedge.

The last step is the execution of the closing wedge (figure 9). For this Plane 5 was chosen as sketcher plane and the first cutting is parallel with Plane 3 and passes through CORA. The second cutting occurs in the same plane and is positioned at the requested correction angle. Correction angle also could a variable parameter. In the figure 10 is shown the tibia prepared for closing high tibial osteotomy.

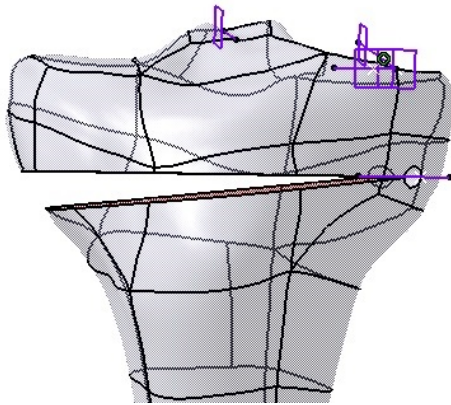

Figure 11. V1=10 mm, V2=6 degree.

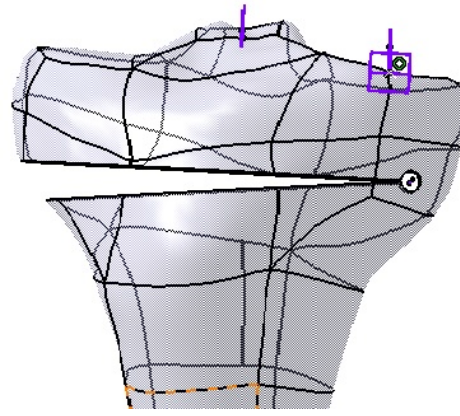

Figure 14. V1=8 mm, V2=6 degree.

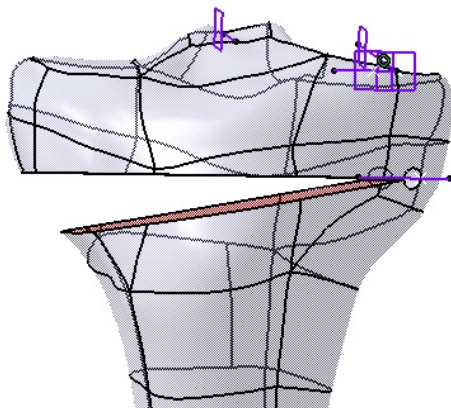

Figure 12. V1=10mm, V2=10 degree.

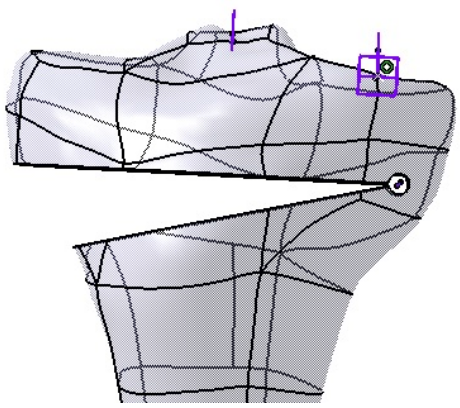

Figure 15. V1=8 mm, V2=14 degree.

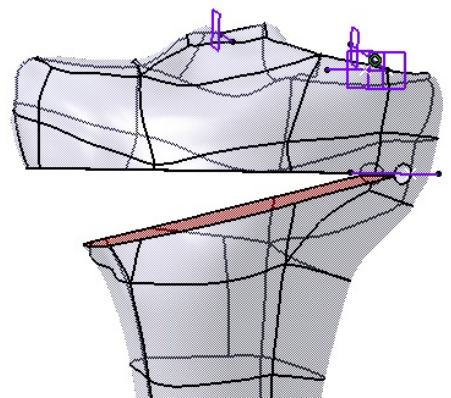

Figure 13. V1=10mm, V2=14 degree.

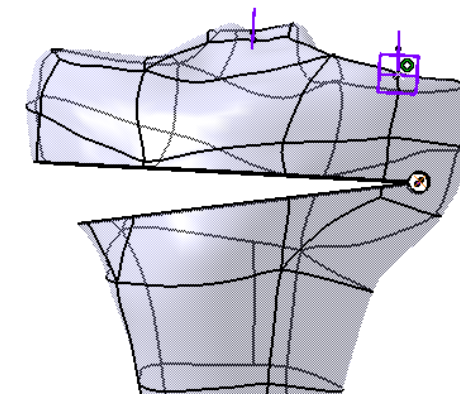

Figure 16. V1=12 mm, V2=10 degree.

The 3D generalized model allows us to obtain a multitude of cutting possibilities only by modifying the presented parameters. In this case for closing high tibial osteotomy the most important parameters could be the position of CORA related to the tangential plane of the lateral cortical surface of the tibia V1 (with values 8, 10 and 12 mm) and the correction angle V2 (with values 6, 10 and 14 degrees). In the figures 11-16 it is shown some combinations of these parameters.

4. Conclusions

The created model was designed so as it will present a high degree of flexibility and so as to ensure that, only by modifying parameters, a large variety of particularized models will result. With the model we can realize any configuration and we can easily prepare the geometric structures in order to undergo the analyses through the finite element method.

The analyses using the finite element method proves its full efficiency in the study of the osteoarticular surgery, being a method that we can use in order to simulate a high range of situations, in the following scenarios: pre-surgery, during the surgery and post-surgery.

Numerical simulation applied of the tibia's behaviour in osteotomy surgeries offers a pretty accurate image of the stress state and allows us to take the most appropriate decision regarding the surgery planning.

The generalised CAD models developed in this article will be used in the further FEM researches in order to establish the best way to performing the surgical procedure CLOSING HIGH TIBIAL OSTEOTOMY.

Acknowledgments

This work is supported by the DiFiCIL project (contract no. 69/08.09.2016, ID P_37_771, web: <http://dificil.grants.ulbsibiu.ro>), co-funded by ERDF through the Competitiveness Operational Programme 2014-2020.t

References

- [1] Mattei L, Lea S, Nicolaci G, Ferrero G, Marmotti A and Castoldi F 2017 *Closing wedge tibial osteotomy: is it an actual procedure nowadays?*, *Annals of Joint, AOJ, Ann Joint*, doi: 10.21037/aoj.2017.06.04
- [2] Landreau P 2019 on Twitter: "*High tibial osteotomy techniques*" <https://twitter.com/plandreau/status/953283838054207489> (accessed on May. 2019)
- [3] Bae D K, Song S J and Yoon K H 2009 Closed-wedge high tibial osteotomy using computer-assisted surgery compared to the conventional technique, *J Bone Joint Surgery Br. 2009 Sep* **91**(9) 1164-71, doi: 10.1302/0301-620X.91B9.22058
- [4] Cofaru I I 2013 *Researches regarding the biomechanics of the axial deviations of the human lower member and the development of the correspondent surgical devices*, Sibiu, Doctoral Thesis
- [5] Amis A 2013, Biomechanics of high tibial osteotomy, *Knee Surgery Sports Traumatology Arthroscopy Jan* **21**(1) 197-205, doi: 10.1007/s00167-012-2122-3
- [6] Kyung D, Sang J, Hwan Kim J and Wan Seo J 2012 Change in limb length after high tibial osteotomy using computer-assisted surgery, *Knee Surgery Sports Traumatology Arthroscopy* **21**(1), DOI: 10.1007/s00167-012-1898-5
- [7] Pena J, Lerner A, Yao J, Salo A and Totterman S 2003 *Evaluation of distance maps from fast GRE MRI as a tool to study the knee joint space*, *Proceedings of SPIE - The International Society for Optical Engineering* 5031:551-562, DOI: 10.1117/12.480435
- [8] Müller-Karger C and Larrazabal A 2005 *Finite Element Bone Model Incorporating Heterogeneity And Anisotropy* From Ct, ISB XX-th Congress - ASB 29th Annual Meeting July 31 - August 5, Cleveland, Ohio
- [9] Soncini M, Vandini L and Redaelli A 2004 Finite Element Analysis Of A Knee Joint Replacement During A Gait Cycle, *Journal Of Applied Biomaterials & Biomechanics* **2** 45-54