

PAPER • OPEN ACCESS

## Modeling and calculation of the powered roller conveyor

To cite this article: N Miloradovi *et al* 2018 *IOP Conf. Ser.: Mater. Sci. Eng.* **393** 012037

View the [article online](#) for updates and enhancements.

### Related content

- [Studies of The Durability of Belt Conveyor Idlers with Working Loads Taken into Account](#)  
Robert Król
- [Reply to 'Comment on "On the stability of a bicycle on rollers"'](#)  
Patricia A Cleary and Pirooz Mohazzabi
- [Design of conveyor type machine with numerical control for manufacturing of extrusion thermoplastic thread](#)  
T N Gorbunova, I I Koltunov and M B Tumanova

# Modeling and calculation of the powered roller conveyor

N Miloradović<sup>1</sup>, R Vujanac<sup>1</sup> and I Miletić<sup>1</sup>

<sup>1</sup>University of Kragujevac, Faculty of Engineering, Sestre Janjić 6, 34000 Kragujevac, Serbia

E-mail: mnenad@kg.ac.rs

**Abstract.** Powered roller conveyor is used as a segment of transport handling system within the warehouse. A model of this conveyor was developed using Autodesk Inventor Professional 3D CAD software. Selection of main elements, drive units and accompanying mechanisms was performed. Dimensions and parameters of the most important elements of the design (rollers, frames and drive arrangement) were determined based on previous calculations, partly presented in the paper. The concept of calculations was adopted according to the procedures defined in the standards and recommendations. The goal was for adopted design to be highly configurable, simple to install and maintain. The application of standard components ensures elimination of product damage and reduction of the costs.

## 1. Introduction

Conveyor systems are used as mechanical handling equipment that moves materials from one location to another. They provide quick and efficient transportation for a wide variety of materials, which make them very popular in the material handling and packaging industries [1].

A roller conveyor has a series of rollers, mounted on bearings, at fixed spacing on two side frames which are fixed or mobile, Figure 1 a). The spacing of rollers depends on the size of the unit loads to be carried, such that the load is carried at least by two rollers at any point of time, Figure 1 b). Roller conveyors are classified into two groups according to the principle of conveying action. These are: unpowered and powered conveyors. The paper presents selection and calculation of one powered roller conveyor.

All or a selected number of rollers of the powered roller conveyor are driven by one or a number of motors depending on the drive unit. The powered roller conveyors may be installed at a slightly inclined position. The load can be moved in both directions by changing the direction of rotation of the rollers (reversing conveyors).

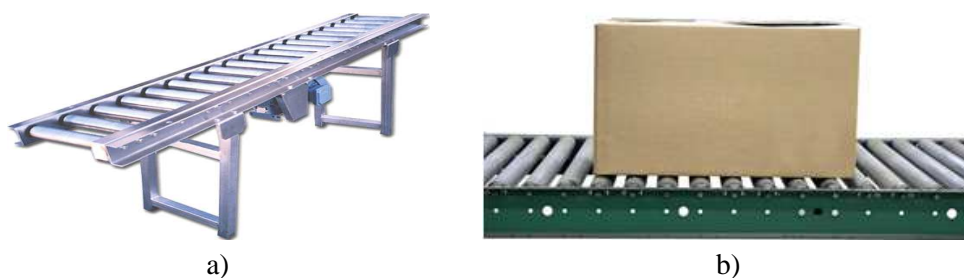
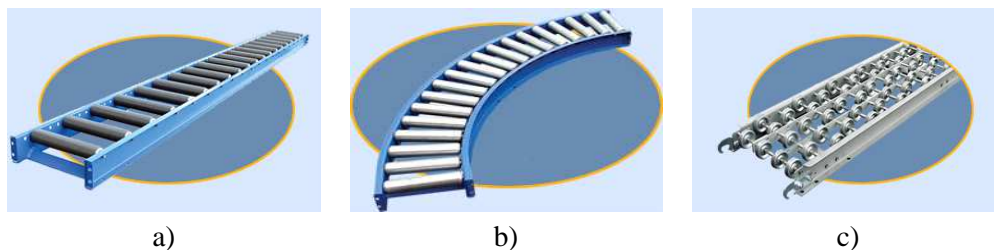

**Figure 1.** Roller conveyor a) general structure b) conveying the load.



Roller conveyors are used for horizontal or slightly inclined conveying of large unit loads (boxes, castings, molds, rolled profiles, pipes, plates, pallets, containers, etc.). They are used for transportation between machines, buildings, in warehousing, foundries, rolling mill plants, manufacturing, assembly and packaging industry. They are also used for storage between work stations and as segment of composite handling system. The limitations of roller conveyors are that they can be used for objects with flat surfaces, and for movement to relatively short distances.

The roller conveyors can have straight sections, Figure 2 a), and curved sections (band units) for changing direction, Figure 2 b). Cylindrical rollers are generally used but designs consisting of series of skate wheels mounted on a shaft or axle are also applied, Figure 2 c).



**Figure 2.** Roller conveyor sections design.

## 2. Calculation

The design of a roller conveyor begins with calculation of conveyor elements for given initial data: total length,  $L=20$  m, inclination angle,  $\beta=3^\circ$ , unit capacity,  $Z=180$  unit/h, dimensions of unit load  $a \times b \times h=1500 \times 500 \times 500$  mm, load weight,  $G=25$  kN, distance between unit loads,  $t=8.1$  m.

The major design calculations should determine the force required to overcome the resistance to motion of the loads and the angle of inclination. Total resistance to motion consists of:

- resistance to rolling of the load on rollers due to friction,
- frictional resistance in the roller bearings and
- resistance due to sliding of the load on the rollers.

The resistance to motion of all pieces of load on the conveyor is [2, 3]:

$$W = m \cdot g \cdot z_o \left[ \left( 2 \cdot \frac{f}{D} + \mu \cdot \frac{d}{D} \right) \cos \beta \pm \sin \beta \right] + m_v \cdot g \cdot z \cdot \frac{\mu \cdot d}{D} \quad (1)$$

where:

$m$  – load unit mass,

$z_o$  – number of loads moving simultaneously on the conveyor,

$f$  – rolling friction factor,

$D$  – roller diameter,

$d$  – roller journal diameter,

$m_v$  – roller mass,

$\mu$  – roller journal coefficient of friction

$z$  – number of rollers,

$\beta$  – inclination angle,

$g$  – acceleration of gravity.

The electric motor power for conveyor drive is:

$$P = \frac{W \cdot v}{\eta} \quad (2)$$

where:

$v$  – velocity of the load,

$\eta$  – total efficiency of the drive mechanism.

All influencing factors were chosen in order to provide efficient and safe movement of materials in accordance with initial technical demands.

### 3. 3D model forming

Calculations of the roller conveyor provided all data and dimensions of the roller conveyor elements. After that, modeling of elements and final assembly of the roller conveyor were conducted. Designed 3D model of the roller conveyor was created using "Autodesk Inventor" software [4]. This software provides forming of final models and animations based on initial concepts and using the standard elements. Major elements of a roller conveyor are:

- driven rollers,
- drive unit,
- carrying structure.

#### 3.1. Driven rollers

The barrel and the shaft portion of the driven roller are integral and are mounted on bearings housed in the frames at two sides. The driven rollers are generally subjected to considerable impact load. They can be made from solid steel forgings or castings or can be fabricated from heavy section of tubes and solid shafts. A shaft with two standard bearings runs through the roller cavity.

Figure 3 shows the roller and shaft assembly. Diameter,  $D$ , and length,  $l$ , of the roller are obtained by calculations and adopted as standard values:  $D=108$  mm and  $l=650$  mm. The diameter of the shaft is  $d=30$  mm.

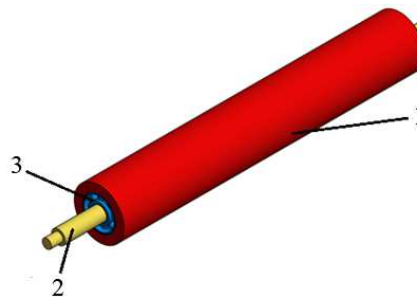

**Figure 3.** Roller and shaft assembly: 1 - roller, 2 - shaft, 3 - bearing.

#### 3.2. Drive unit

One electric motor with suitable transmission arrangement is used to drive all the driven rollers. The motor, through a gear box, drives a roller shaft. The transmission of power comes to one roller, and the other driven rollers are connected to this driven roller by series of sprockets and chains. The adopted electric motor (1), gearbox (2) and clutch (3) are presented in Figure 4. The electric motor is mounted on corresponding stand made of standard profiles (50 mm x 50 mm) using standard bolts, Figure 5.

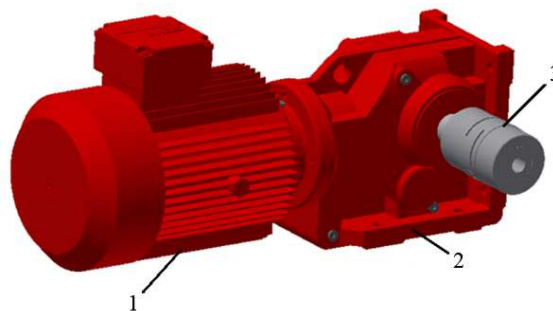

**Figure 4.** Drive unit assembly.

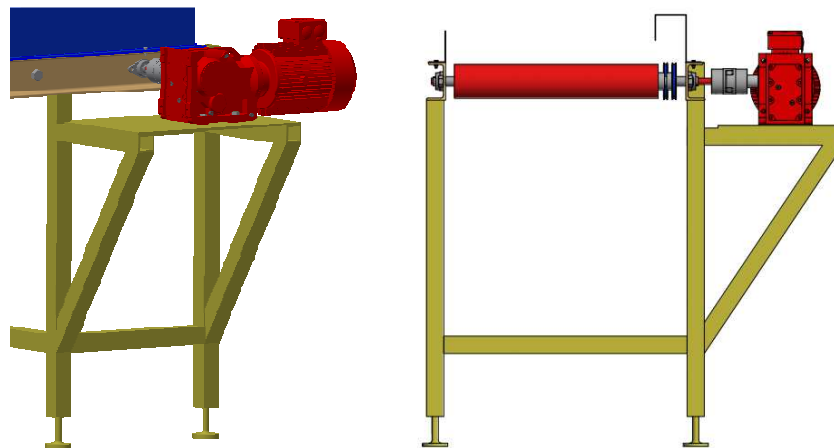

**Figure 5.** The electric motor on the stand.

### 3.3. Carrying structure

The rollers are supported at their journals on two set of frames at two ends. The carrying structure is made of several standard steel profiles (50 mm x 50 mm). The profiles are placed vertically, in two lines, eleven elements on each side, spaced at 1,8 m. Longitudinal profiles are placed between vertical profiles to obtain stable construction. All mentioned profiles are joined by welding and they make the carrying structure (frame), Figure 6.

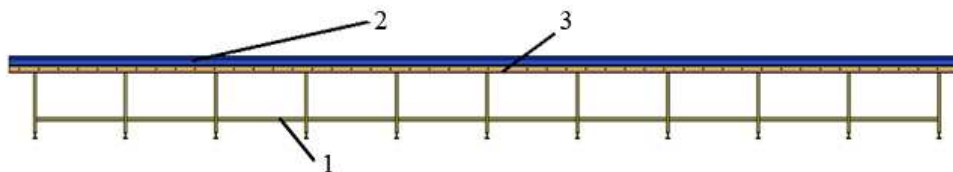

**Figure 6.** Detail of the carrying structure of the roller conveyor: 1 - carrying structure, 2 - protective sheet, 3 - U-profile.

Two U-profiles (or rails) are placed at the top of the carrying structure to hold the rollers and prevent the falling of load. These profiles are connected to the frame using standard bolts. The protective sheets are also placed along the conveyor to prevent intrusion of dust into chain transmission and to protect workers against injuries in the vicinity of the conveyor. Figure 6 shows the carrying structure of the roller conveyor with mounted profiles and protective sheets.

The enhanced view of carrying structure, U-profiles and protective sheets is presented in Figure 7, while Figure 8 shows the complete form of carrying structure.

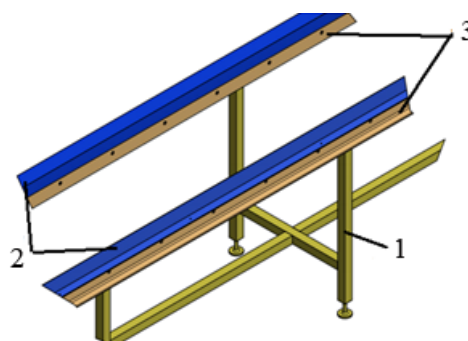

**Figure 7.** The enhanced view of carrying structure, U-profiles and protective sheets: 1 - carrying structure, 2 - protective sheet, 3 - U-profile.

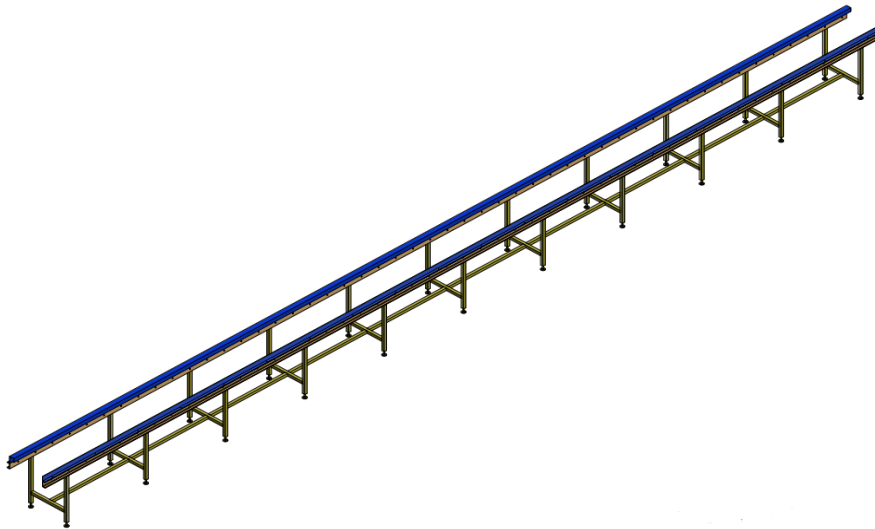

**Figure 8.** The carrying structure of the roller conveyor.

After all elements were assembled, an overall model of the powered roller conveyor was obtained and presented in Figure 9.

Maintenance of this roller conveyor demands the regular lubrication of chain transmission and checking of oil lever in the gearbox. In order to increase the lifetime of the conveyor, regular servicing is needed. The modeled conveyor is intended for operation in warehouses and, thus, it is protected from external weather conditions. This means that this conveyor should have the longer lifetime than average.

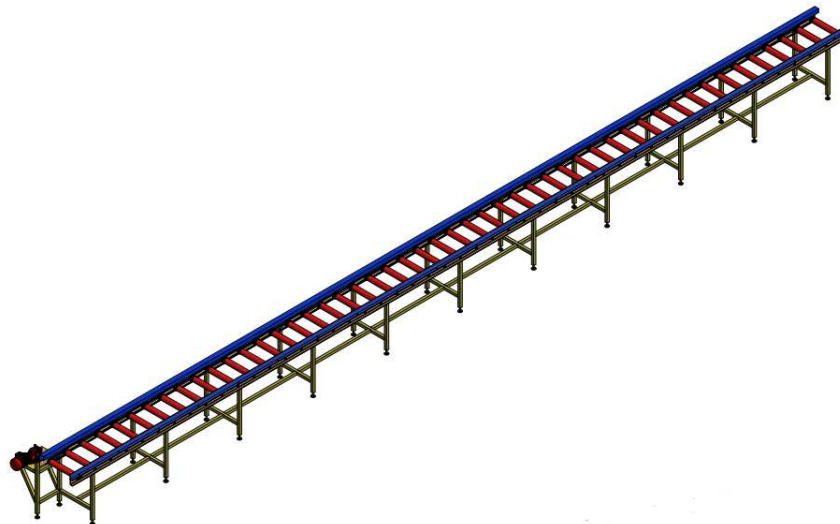

**Figure 9.** Overall model of the powered roller conveyor.

#### **4. Conclusion**

The roller conveyors are one of the most cost-effective and efficient conveying solutions. They are highly configurable and easy to install. Thanks to the use of standard components a variety of arrangements can be made. Due to minimum moving parts, they have reduced power consumption and require only low maintenance.

Creation of a 3D model of the roller conveyor was described based on demanded input parameters. Detailed calculation of the powered roller conveyor according to the set requirements in terms of its size and transport capacity was conducted. Modeling of the complete roller conveyor was conducted

according to the dimensions obtained by calculation. Also, technical documentation showing the complete model was generated. The calculation and selection of main elements of the roller conveyor were carried out and the final results are presented in the paper.

The presented model can be used for analysis of different constructions of roller conveyors after minimal modifications. It is possible to change the number of driven rollers in a quick and easy manner depending on the new user requirements.

With the use of special modules within the framework of the software program, it is possible to perform a detailed analysis in terms of deformation and stress of carrying structure of the roller conveyor.

### References

- [1] Siddhartha R 2008 *Introduction to Materials Handling*, New Age International Publishers
- [2] Gašić M 2017 *Transport Machinery - Excerpts from the Theory with Examples*, Faculty of Mechanical and Civil Engineering in Kraljevo
- [3] Tošić S 1999 *Transport Machines - Mechanization of Transport*, Faculty of Mechanical Engineering in Belgrade
- [4] Waguespack C 2014 *Mastering Autodesk Inventor 2015 and Autodesk Inventor LT 2015*, John Wiley & Sons, Inc