

The ABC Index Conundrum

Ivan Gutman^a, Boris Furtula^a, Mohammad B. Ahmadi^b, Seyyed A. Hosseini^b, Pouria Salehi Nowbandegani^b, Maryam Zarrinderakht^b

^aFaculty of Science, University of Kragujevac, P. O. Box 60, 34000 Kragujevac, Serbia

^bDepartment of Mathematics, College of Sciences, Shiraz University 71454, Shiraz, Iran

Abstract. The atom–bond connectivity (*ABC*) index of a graph G is defined as the sum over all pairs of adjacent vertices u, v , of the terms $\sqrt{[d(u) + d(v) - 2]/[d(u)d(v)]}$, where $d(v)$ denotes the degree of the vertex v of the graph G . Whereas the finding of the graphs with the greatest *ABC*-value is an easy task, the characterization of the graphs with smallest *ABC*-value, in spite of numerous attempts, is still an open problem. What only is known is that the connected graph with minimal *ABC* index must be a tree, and some structural features of such trees have been determined. Several conjectures on the structure of the minimal-*ABC* trees, were disproved by counterexamples.

In this review we present the state of art of the search for minimal-*ABC* trees, and provide a complete bibliography on *ABC* index.

1. Introduction

Let G be a graph and let $d(v)$ denote the degree (= number of first neighbors) of the vertex v of G . Then the *atom–bond connectivity* (*ABC*) index of G is defined as [14]:

$$ABC = ABC(G) = \sum_{u \sim v} \sqrt{\frac{d(u) + d(v) - 2}{d(u)d(v)}}$$

with summation going over all pairs of adjacent vertices of G .

The applicability of the *ABC* index in chemical thermodynamics [13, 14, 23] and other areas of chemistry [3, 11, 20, 24, 33] is nowadays well documented. On the other hand, *ABC* is just one of about a dozen of graph invariants of the form

$$\sum_{u \sim v} f(d(u), d(v))$$

that have been examined in the recent chemical literature, and considered as molecular structure descriptors; for details see [12, 27, 28]

2010 *Mathematics Subject Classification.* Primary 05C07; Secondary 05C90

Keywords. Atom–bond connectivity index; *ABC* index; Trees; Extremal trees

Received: 10 July 2012; Accepted: 18 October 2012

Communicated by Dragan Stevanović

I. G. and B. F. thank the Serbian Ministry of Education and Science (Grant No. 174033) for financial support during the work on this paper.

Email addresses: gutman@kg.ac.rs (Ivan Gutman), furtula@kg.ac.rs (Boris Furtula), mbahmadi@shirazu.ac.ir (Mohammad B. Ahmadi), ssahosseini@shirazu.ac.ir (Seyyed A. Hosseini), pouria.salehi@gmail.com (Pouria Salehi Nowbandegani), zarrin.maryam@yahoo.com (Maryam Zarrinderakht)

In the last few years there is an increased interest for the mathematical properties of the ABC index, resulting in quite a few published papers [1, 2, 4–10, 15–19, 21, 22, 25, 26, 29–32, 34].

From a mathematical point of view, the first question that needs to be addressed is about the minimal and maximal values of the ABC index in the class of graphs of a given order n . Because for a graph G , consisting of disconnected components G_1 and G_2 , $ABC(G) = ABC(G_1) + ABC(G_2)$, and because $ABC(G) = 0$ if and only if G is edgeless, it is purposeful to restrict the considerations to connected graphs.

The following results could be obtained quite easily:

Theorem 1.1. [4, 9] *Among graphs of order n , the complete graph has greatest ABC index. This maximal- ABC graph is unique.*

Theorem 1.2. [16] *Among trees of order n , the star has greatest ABC index. This maximal- ABC tree is unique.*

Theorem 1.3. [4, 9] *The connected graph of order n with smallest ABC index must be a tree. This minimal- ABC tree needs not be unique.*

At the first glance, characterizing the minimal- ABC tree did not look as a particularly difficult problem, and was expected to be solvable by standard and routine techniques. After the initial failures to achieve this goal, the research continued in two different, but complementary, directions: (a) finding necessary, but not sufficient structural conditions that the minimal- ABC trees must satisfy, and (b) computer-aided search for these trees. We outline the results obtained along these lines in the two subsequent sections.

2. Structural features of the minimal- ABC trees

Let G be a graph on n vertices, and let its vertex set be $V(G)$. As before, by $d(v)$ is denoted the degree of the vertex $v \in V(G)$. In order to avoid complications encountered in the case of trees with the first few values of n , in this section we assume that $n \geq 10$. The minimal- ABC trees with 9 and fewer vertices are depicted in Fig. 1.

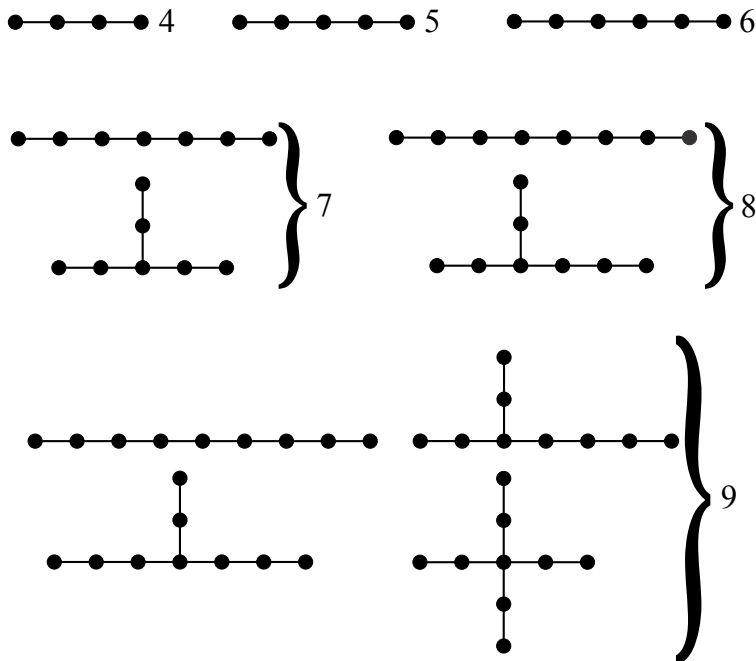

Figure 1: Trees of order n with smallest ABC indices, for $4 \leq n \leq 9$.

Let $1 \leq k \leq n - 3$ and let $v_0, v_1, \dots, v_k, v_{k+1} \in V(G)$. We say that the vertices v_1, \dots, v_k, v_{k+1} form a path in G if

- v_{i-1} is adjacent to v_i , for $i = 1, 2, \dots, k + 1$, and
- $d(v_i) = 2$ for $1 \leq i \leq k$, and
- $d(v_0) \geq 3$ and $d(v_{k+1}) \neq 2$.

If $d(v_{k+1}) \geq 3$, then the vertices v_1, \dots, v_k form an *internal path* in the graph G . Its length is k .

If, in turn, $d(v_{k+1}) = 1$, then the vertices v_1, \dots, v_k, v_{k+1} form a *pendent path* in the graph G . Its length is $k + 1$.

Theorem 2.1. [22] *The n -vertex tree with minimal ABC index does not contain internal paths of any length $k \geq 1$.*

Theorem 2.2. [22] *The n -vertex tree with minimal ABC index does not contain pendent paths of length $k \geq 4$.*

Theorem 2.3. [26] *The n -vertex tree with minimal ABC index does not contain pendent paths of length 1.*

In fact, Theorem 2.3 is a special case of a somewhat stronger result:

Theorem 2.4. [26] *In a tree with minimal ABC index, every vertex of degree one is adjacent to a vertex of degree two.*

According to Theorems 2.2 and 2.3, a minimal-ABC tree can possess only pendent paths of length 2 and 3. Moreover, we have:

Theorem 2.5. [22] *An n -vertex tree with minimal ABC index contains at most one pendent path of length 3.*

The next simple result is stated here for the first time.

Theorem 2.6. *If a minimal-ABC tree possesses three mutually adjacent vertices v_1, v_2, v_3 , such that*

$$d(v_1) \geq d(v_2) > d(v_3) \geq 2 \tag{1}$$

then v_3 must not be adjacent to both v_1 and v_2 .

Proof. If v_3 is adjacent to both v_1 and v_2 , then the contribution to ABC of the two pairs of adjacent vertices is

$$X_{132} = \sqrt{\frac{d(v_1) + d(v_3) - 2}{d(v_1)d(v_3)}} + \sqrt{\frac{d(v_2) + d(v_3) - 2}{d(v_2)d(v_3)}}$$

whereas if v_2 is adjacent to both v_1 and v_3 , the respective contribution is

$$X_{123} = \sqrt{\frac{d(v_1) + d(v_2) - 2}{d(v_1)d(v_2)}} + \sqrt{\frac{d(v_2) + d(v_3) - 2}{d(v_2)d(v_3)}}.$$

It is now straightforward to show that the condition $X_{123} < X_{132}$ can be reduced to

$$2[d(v_2) - d(v_3)] < d(v_1)[d(v_2) - d(v_3)]$$

which is always obeyed provided (1) holds. \square

Theorem 2.1 has a noteworthy consequence:

Corollary 2.7. *Let T be a tree with minimal ABC index. Then the subgraph induced by the vertices of T whose degrees are greater than two is also a tree.*

Two analogous consequences of Theorem 2.6 are:

Corollary 2.8. *Let T be a tree with minimal ABC index. Denote by Δ the greatest vertex degree of T . Let D be any integer, such that $0 \leq D \leq \Delta - 1$. Then the subgraph induced by the vertices of T whose degrees are greater than D is also a tree. In particular, the subgraph of T , induced by the vertices of degree Δ is also a tree.*

At the time of writing of this review (July 2012), the results stated in this section seem to be the only exactly proven structural features of the trees whose ABC indices are minimal.

3. Computer search for minimal-ABC trees

In an attempt to guess the general structure of the n -vertex tree(s) with minimal ABC index, all trees of order n were checked, up to n as large as possible, and the tree(s) with smallest ABC singled out [17, 22]. Whereas the evaluating of the ABC index for any particular tree is an elementary computational task, the true problem is that with increasing value of n , the number of trees rapidly increases, see Table 1. In spite of technical difficulties, calculations of this kind were performed up to $n = 31$ [22]; the respective computational details are described in [17].

n	no. of trees	n	no. of trees
15	7 741	25	104 636 890
16	19 320	26	279 793 450
17	48 629	27	751 065 460
18	123 867	28	2 023 443 032
19	317 955	29	5 469 566 585
20	823 065	30	14 830 871 802
21	2 144 505	31	40 330 829 030
22	5 623 756	32	109 972 410 221
23	14 828 074	33	300 628 862 480
24	39 299 897	34	823 779 631 721

Table 1: Number of trees with n vertices.

In Figs. 2 and 3 are depicted the minimal-ABC trees for $n = 21, 22, \dots, 29$ and $n = 30, 31$.

Let us, for a moment, stop at the results obtained for $n \leq 29$, cf. Fig. 2.

It was hoped that after some sufficiently large n , the form of the minimal-ABC trees will emerge, enabling one to formulate a conjecture on their general structure. Initially, success was in sight. From Fig. 2 (as well as from the minimal-ABC trees of order smaller than 21 [22]), the following structural features can be envisaged:

Conjecture 3.1. (a) *The minimal-ABC tree has a single high-degree vertex, v_0 .*
 (b) *To the vertex v_0 only three types of branches are attached. These are B_1 , B_2 , and B_3 shown in Fig. 4.*

For $10 \leq n \leq 29$, the minimal-ABC tree of order n was found to be unique, except for $n = 16$ (when there are two distinct minimal-ABC trees). This led to:

Conjecture 3.2. *For $n > 16$ the minimal-ABC tree of order n is unique.*

Conjecture 3.1 was used for guessing which tree with $n > 29$ vertices has the smallest ABC-value. According to it, the minimal-ABC tree has

$$n = 1 + 2a_1 + 5a_2 + 7a_3 \quad (2)$$

vertices, where a_1 , a_2 , and a_3 are, respectively, the number of branches of type B_1 , B_2 , and B_3 , attached to the central vertex, see Fig. 4. For a given value of n , formula (2) is a Diophantine equation, having only a small number of solutions. For instance, if $n = 30$, then Eq. (2) has only 7 solutions (a_1, a_2, a_3) namely: $(0, 3, 2)$, $(1, 4, 1)$, $(2, 5, 0)$, $(4, 0, 3)$, $(5, 1, 2)$, $(6, 2, 1)$, and $(11, 0, 1)$. The ABC-values of the respective seven trees are easily computed and the tree with $(a_1, a_2, a_3) = (1, 4, 1)$ is found to have the smallest ABC index. By direct checking all the 14 830 871 802 trees of order 30 it was shown that, indeed, this is the (unique) minimal-ABC tree, cf. Fig. 3. In the same manner, it was possible to guess which 31-vertex tree has the

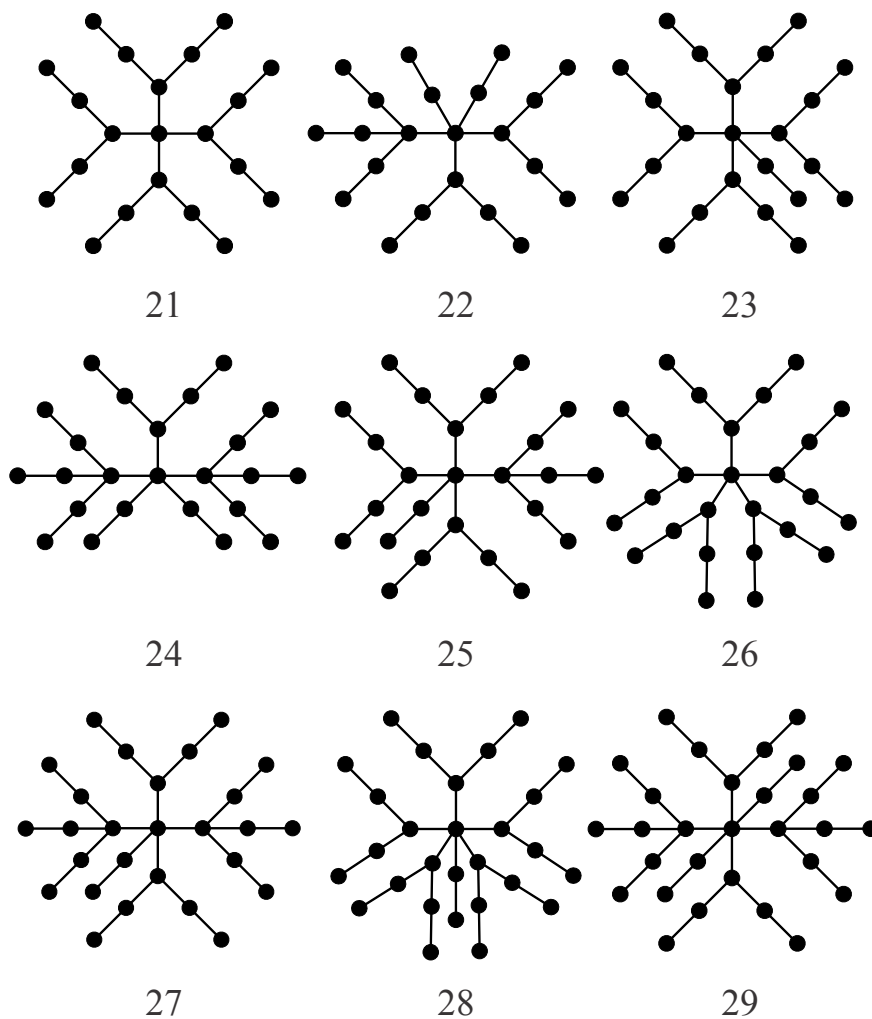

Figure 2: Trees with $n = 21, 22, \dots, 29$ vertices with minimal value of the ABC index. These were determined by calculating ABC of all n -vertex trees.

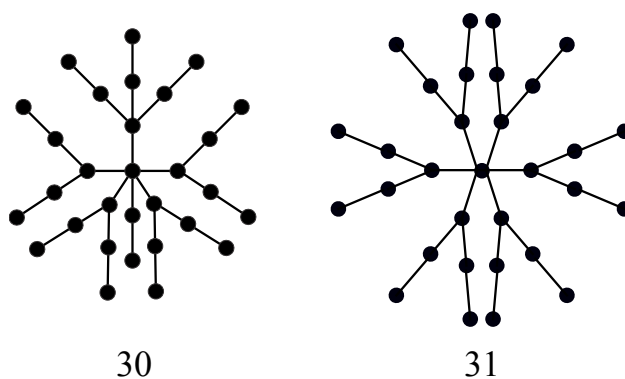

Figure 3: Trees of order 30 and 31 with smallest ABC index.

smallest ABC -index [22], and this prediction was confirmed by checking all the 40 330 829 030 trees of order 31, cf. Fig. 3. The success of this approach was encouraging, but its direct “brute-force” verification for

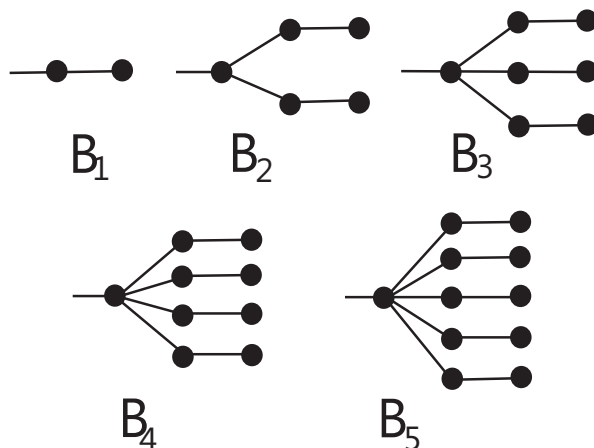

Figure 4: The branches considered in the search for minimal-ABC trees.

trees with more that 31 vertices was not feasible [17].

In order to evade this difficulty, the model (2) was extended as

$$n = 1 + 2a_1 + 5a_2 + 7a_3 + 9a_4 + 11a_5 + \eta \tag{3}$$

where a_4 and a_5 are the number of branches of the type B_4 and B_5 (depicted in Fig. 4), and $\eta \in \{0, 1\}$ is the number of pendent paths of length 3, cf. Theorem 2.5. In the model (3) it is still assumed that Conjecture 3.1(a) holds, but in addition to the branches $B_1, B_2,$ and $B_3,$ some of their extension are also considered as possible. If the minimal-ABC solution of the Diophantine equation (3) would yield $a_4 = a_5 = \eta = 0$ and would be unique, then Conjectures 3.1 and 3.2 would be corroborated, yet not confirmed.

Calculations based on the model (3) were performed up to $n = 700$. These showed that the Conjectures 3.1 and 3.2 are not generally obeyed.

Conjecture 3.1(b) is first time violated at $n = 80$, when the minimal-ABC solution of (3) has $a_4 = 1$. For still greater values of n solutions with $a_4 > 0$ were frequently encountered, but $a_5 = 0$ was found in all cases up to $n = 700$.

Minimal-ABC solutions of (3) with $\eta = 1$ were encountered, first time at $n = 161$, and then frequently for greater values of n .

Also at $n = 161$, the first violation of Conjecture 3.2 was detected, see Fig. 5. Yet, it appears that such violations are remarkably rare.

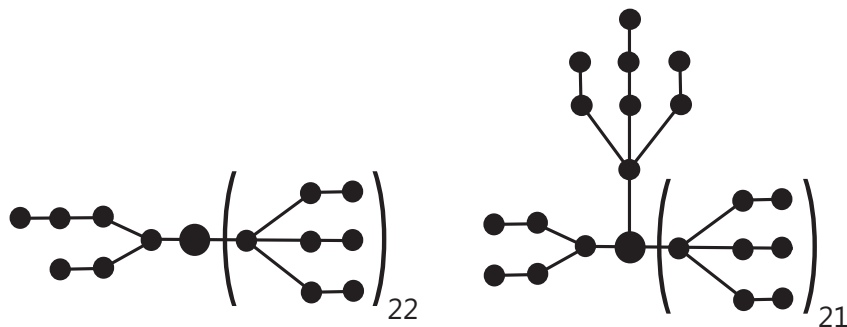

Figure 5: The two minimum-ABC solutions of Eq. (3) for $n = 161$. This is the first such pair after $n = 16$. The next such doublet occurs already at $n = 168$, but for $169 \leq n \leq 700$ no more multiplsets were detected.

4. A modulo 7 conjecture and further counterexamples

The solutions of the model (3), pertaining to smallest ABC index, lead to trees whose structure do not follow any conceivable pattern. However, after a sufficiently large value of n , a peculiar modulo 7 regularity could be envisaged, which we state here in the form of the following conjecture [21]:

- Conjecture 4.1.** (i) If $n \equiv 0 \pmod{7}$, $k \geq 21$, and $n = 7k + 28$, then the minimum-ABC tree has the structure T_7 shown in Fig. 6. The smallest such tree has $n = 175$ vertices.
- (ii) If $n \equiv 1 \pmod{7}$, $k \geq 9$, and $n = 7k + 1$, then the minimum-ABC tree has the structure T_1 shown in Fig. 6. The smallest such tree has $n = 64$ vertices.
- (iii) If $n \equiv 2 \pmod{7}$, $k \geq 23$, and $n = 7k + 9$, then the minimum-ABC tree has the structure T_2 shown in Fig. 6. The smallest such tree has $n = 170$ vertices.
- (iv) If $n \equiv 3 \pmod{7}$, $k \geq 10$, and $n = 7k + 10$, then the minimum-ABC tree has the structure T_5 shown in Fig. 6. The smallest such tree has $n = 80$ vertices.
- (v) If $n \equiv 4 \pmod{7}$, $k \geq 6$, and $n = 7k + 11$, then the minimum-ABC tree has the structure T_4 shown in Fig. 6. The smallest such tree has $n = 53$ vertices.
- (vi) If $n \equiv 5 \pmod{7}$, $k \geq 14$, and $n = 7k + 19$, then the minimum-ABC tree has the structure T_6 shown in Fig. 6. The smallest such tree has $n = 117$ vertices.
- (vii) If $n \equiv 6 \pmod{7}$, $k \geq 8$, and $n = 7k + 6$, then the minimum-ABC tree has the structure T_3 shown in Fig. 6. The smallest such tree has $n = 62$ vertices.

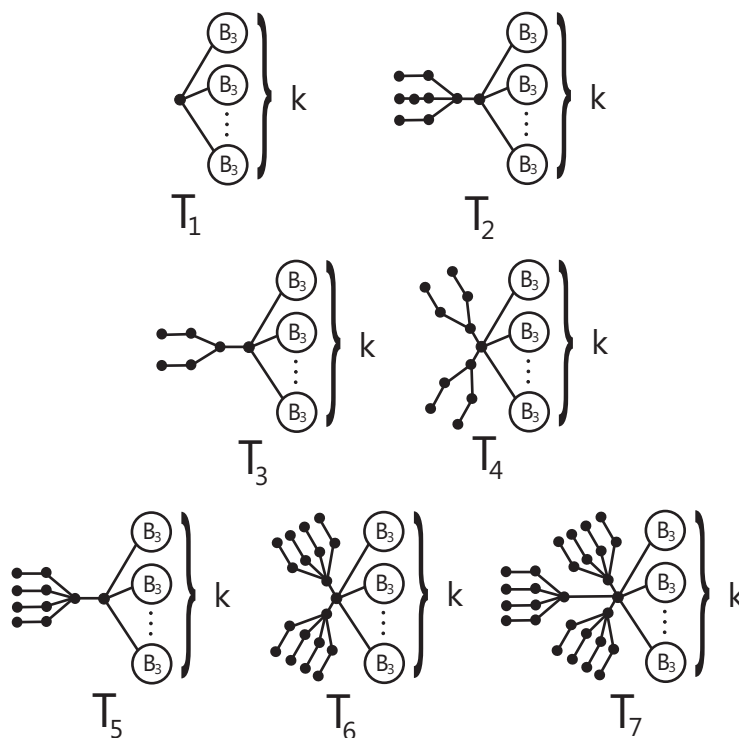

Figure 6: The seven types of minimum-ABC trees from Conjecture 4.1; the form of the branch B_3 is shown in Fig. 4.

Since Conjecture 4.1 was obtained using the model (3), the uniqueness of the central high-degree vertex, and thus the validity of Conjecture 3.1(a), was a priori assumed.

Note that according to Conjecture 4.1, for sufficiently large values of n , the minimal-ABC tree of order n is unique (in harmony with Conjecture 3.2). If $n \equiv 2 \pmod{7}$, then these trees possess a pendent path of length three ($\eta = 1$), whereas otherwise $\eta = 0$.

In graph theory it often happens that the structure of extremal graphs of order n is complicated and irregular for smaller values of n , and begins to follow a reasonably simple pattern when n is large enough. Conjecture 4.1 looked just to be a result of this kind.

Alas, counterexamples to Conjecture 4.1 were recently discovered [1, 2].

In [2] it was shown that for $n = 7k + 9$, $k \geq 169$, there exist trees, shown in Fig. 7, whose ABC-value is smaller than of the trees T_2 from Conjecture 4.1(iii). The smallest such tree has $n = 1185$ vertices. In other words, Conjecture 4.1(iii) is violated at $n \geq 1185$.

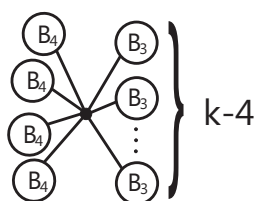

Figure 7: Trees violating Conjecture 4.1 for $n \equiv 2 \pmod{7}$ and $n \geq 1185$; the branches B_3 and B_4 are shown in Fig. 4.

In [1] a class of trees with $n = 7k + 11$, $k \geq 43$, i. e., $n \geq 312$ was constructed, shown in Fig. 8, having ABC indices smaller than those predicted by the model (3). By this, these trees provide a counterexample for Conjecture 4.1(v). Even worse, these trees possess two high-degree vertices, thus violating Conjecture 3.1(a) or, what is the same, possess a branch structurally different from the branches B_i , $i = 2, 3, 4, \dots$, thus violating Conjecture 3.2(b) and its extension.

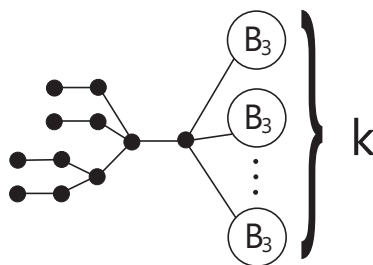

Figure 8: A class of trees violating the model (3) and violating Conjectures 3.1(a) and 4.1.

5. Concluding remarks

In spite of the numerous mathematical and computer-aided studies, all conjectures and guesses on the general structure of trees with smallest atom-bond connectivity index failed. At the present moment, only what can be answered to the question:

“Which are the trees of order n with smallest ABC index?”

is:

“We don’t know.”

Yet, our ignorance is not total. Some fragments of the answer are seen or believed to be seen.

References

- [1] M. B. Ahmadi, S. A. Hosseini, P. Salehi Nowbandegani, On trees with minimal atom bond connectivity index, *MATCH Communications in Mathematical and in Computer Chemistry* 69 (2013), 559–563.
- [2] M. B. Ahmadi, S. A. Hosseini, M. Zarrinderakht, On large trees with minimal atom–bond connectivity index, *MATCH Communications in Mathematical and in Computer Chemistry* 69 (2013), 565–569.
- [3] M. B. Ahmadi, M. Sadeghimehr, Atom bond connectivity index of an infinite class $NS_1[n]$ of dendrimer nanostars, *Optoelectronics and Advanced Materials – Rapid Communications* 4 (2010) 1040–1042.
- [4] J. Chen, X. Guo, Extreme atom–bond connectivity index of graphs, *MATCH Communications in Mathematical and in Computer Chemistry* 65 (2011) 713–722.
- [5] J. Chen, X. Guo, The atom–bond connectivity index of chemical bicyclic graphs, *Applied Mathematics – A Journal of Chinese Universities*, in press.
- [6] J. Chen, J. Liu, On atom–bond connectivity index of bicyclic graphs, *Journal of Guangxi Teachers Education University (Natural Science Edition)* 28 (2011) 8–12 (in Chinese).
- [7] J. Chen, J. Liu, X. Guo, Some upper bounds for the atom–bond connectivity index of graphs, *Applied Mathematics Letters* 25 (2012) 1077–1081.
- [8] K. C. Das, Atom–bond connectivity index of graphs, *Discrete Applied Mathematics* 158 (2010) 1181–1188.
- [9] K. C. Das, I. Gutman, B. Furtula, On atom–bond connectivity index, *Chemical Physics Letters* 511 (2011) 452–454.
- [10] K. C. Das, I. Gutman, B. Furtula, On atom–bond connectivity index, *Filomat* 26 (2012) 733–738.
- [11] K. C. Das, N. Trinajstić, Comparison between first geometric–arithmetic index and atom–bond connectivity index, *Chemical Physics Letters* 497 (2010) 149–151.
- [12] T. Došlić, B. Furtula, A. Graovac, I. Gutman, S. Moradi, Z. Yarahmadi, On vertex–degree–based molecular structure descriptors, *MATCH Communications in Mathematical and in Computer Chemistry* 66 (2011) 613–626.
- [13] E. Estrada, Atom–bond connectivity and the energetic of branched alkanes, *Chemical Physics Letters* 463 (2008) 422–425.
- [14] E. Estrada, L. Torres, L. Rodríguez, I. Gutman, An atom–bond connectivity index: Modelling the enthalpy of formation of alkanes, *Indian Journal of Chemistry* 37A (1998) 849–855.
- [15] G. A. Fath–Tabar, B. Vaez–Zadah, A. R. Ashrafi, A. Graovac, Some inequalities for the atom–bond connectivity index of graph operations, *Discrete Applied Mathematics* 159 (2011) 1323–1330.
- [16] B. Furtula, A. Graovac, D. Vukičević, Atom–bond connectivity index of trees, *Discrete Applied Mathematics* 157 (2009) 2828–2835.
- [17] B. Furtula, I. Gutman, M. Ivanović, D. Vukičević, Computer search for trees with minimal *ABC* index, *Applied Mathematics and Computations*, 219 (2012) 767–772.
- [18] L. Gan, H. Hou, B. Liu, Some results on atom–bond connectivity index of graphs, *MATCH Communications in Mathematical and in Computer Chemistry* 66 (2011) 669–680.
- [19] L. Gan, B. Liu, Z. You, The *ABC* index of trees with given degree sequence, *MATCH Communications in Mathematical and in Computer Chemistry* 68 (2012) 137–145.
- [20] A. Graovac, M. Ghorbani, A new version of the atom–bond connectivity index, *Acta Chimica Slovenica* 57 (2010) 609–612.
- [21] I. Gutman, B. Furtula, Trees with smallest atom–bond connectivity index, *MATCH Communications in Mathematical and in Computer Chemistry* 68 (2012) 131–136.
- [22] I. Gutman, B. Furtula, M. Ivanović, Notes on trees with minimal atom–bond connectivity index, *MATCH Communications in Mathematical and in Computer Chemistry* 67 (2012) 467–482.
- [23] I. Gutman, J. Tošović, S. Radenković, S. Marković, On atom–bond connectivity index and its chemical applicability, *Indian Journal of Chemistry* 51A (2012) 690–694.
- [24] X. Ke, Atom–bond connectivity index of benzenoid systems and fluoranthene congeners, *Polycyclic Aromatic Compounds* 32 (2012) 27–35.
- [25] W. Lin, T. Gao, X. Lin, Q. Chen, On the atom–bond connectivity index of connected graphs with a given degree sequence, *MATCH Communications in Mathematical and in Computer Chemistry*, 69 (2013) 571–578.
- [26] W. Lin, X. Lin, T. Gao, X. Wu, Proving a conjecture of Gutman concerning trees with minimal *ABC* index, *MATCH Communications in Mathematical and in Computer Chemistry* 69 (2013), 549–578.
- [27] R. Todeschini, V. Consonni, *Handbook of Molecular Descriptors*, Wiley–VCH, Weinheim, 2000.
- [28] R. Todeschini, V. Consonni, *Molecular Descriptors for Chemoinformatics*, Wiley–VCH, Weinheim, 2009.
- [29] T. S. Vassilev, L. J. Huntington, On the minimum *ABC* index of chemical trees, *Applied Mathematics* 2 (2012) 8–16.
- [30] R. Xing, B. Zhou, Extremal trees with fixed degree sequence for atom–bond connectivity index, *Filomat* 26 (2012) 683–688.
- [31] R. Xing, B. Zhou, F. Dong, On atom–bond connectivity index of connected graphs, *Discrete Applied Mathematics* 159 (2011) 1617–1630.
- [32] R. Xing, B. Zhou, Z. Du, Further results on atom–bond connectivity index of trees, *Discrete Applied Mathematics* 158 (2010) 1536–1545.
- [33] J. Yang, F. Xia, H. Cheng, The atom–bond connectivity index of benzenoid systems and phenylenes, *International Mathematical Forum* 6 (2011) 2001–2005.
- [34] B. Zhou, R. Xing, On atom–bond connectivity index, *Zeitschrift für Naturforschung* 66a (2011) 61–66.